

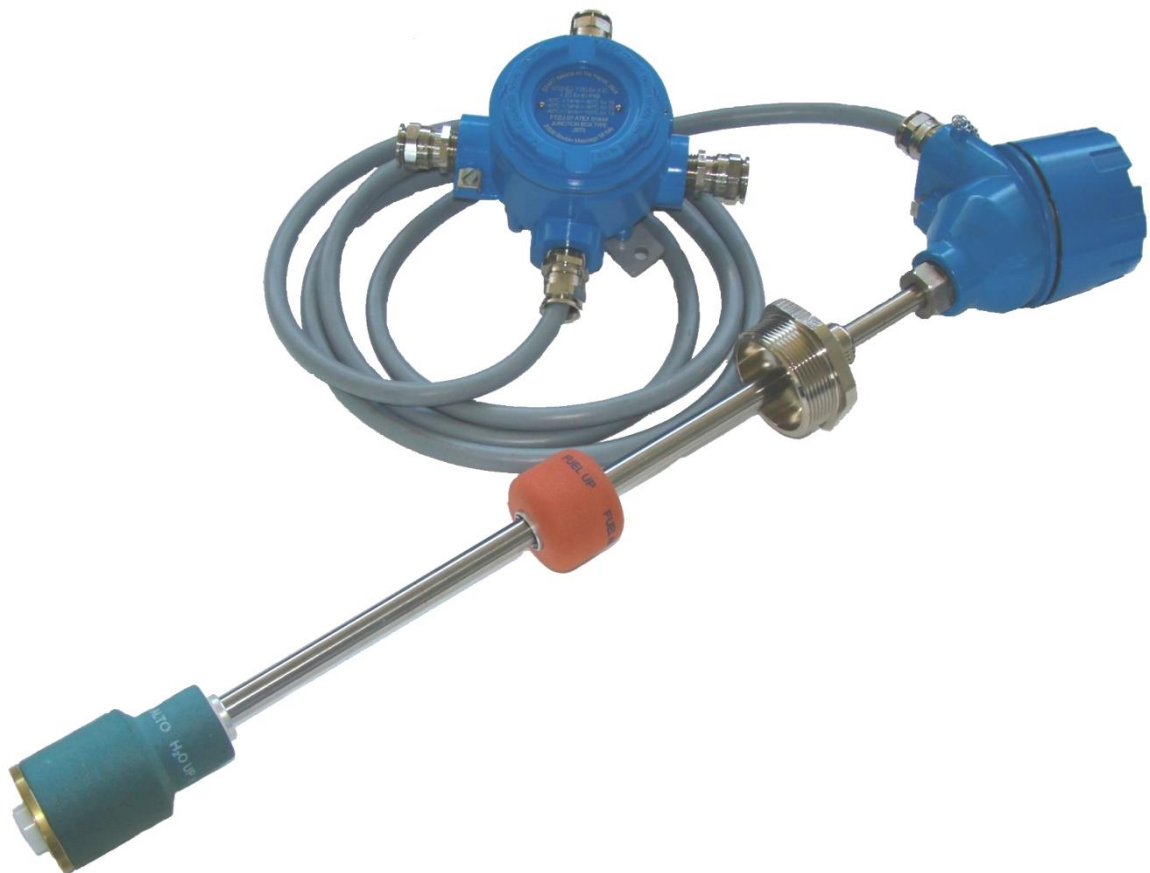

INSTALLATION MANUAL

XMT MAGNETOSTRICTIVE LEVEL PROBE



INDEX

INDEX.....	2
REVISION INDEX.....	2
INTRODUCTION.....	3
GENERAL WARNINGS.....	3
DESCRIPTION.....	4
MAIN COMPONENTS.....	5
MECHANICAL INSTALLATION.....	6
INSTALLATION PROCEDURE.....	6
ELECTRICAL CONNECTION.....	8
EXTERNAL INSTALLATION SCHEME.....	9
RS485 BUS CONNECTION:.....	10
MARKING AND SERIAL NUMBER.....	11
ELECTRONIC BOARD.....	12
ATEX CERTIFICATE AND CESI NOTIFICATION.....	13

REVISION INDEX

DATE	REVISION NUMBER	DESCRIPTION
	0	INITIAL RELEASE
09/2011	1	General revision
09/2014	2	General amendments and layout revision
04/2015	3	Notification



This product complies with EU Directive 2012/19/UE.

The crossed-bin symbol fixed on the device indicates that the product, at the end of its useful life, should be disposed of separately from household waste, must be taken to a collection point for electrical and electronic equipment.

Nota: Start italiana Srl, in respect of its quality duty may modify its production and data shown into this manual. This manual cannot be copied, neither partially, without authorization.

INTRODUCTION

This manual gives all the installation and use instructions for XMT level probes.

GENERAL WARNINGS

- Before the installation and use of the equipment please carefully read the instructions given into this manual.
- The manufacturer is not responsible of any possible operation not mentioned into this manual.
- Any failure or faulty operation would occur to the equipment, please refer to the authorized personnel for maintenance or directly to the manufacturer only.
- The manufacturer refuses all responsibility for any eventual injury and/or damage to things caused to the non-observance of the safety regulations.
- The assigned personnel is required to know all the safety regulations relative to the hereby described equipment.
- Any doubt may occur about the equipment running please refer to the authorized personnel for maintenance or directly to the manufacturer.
- Tampering releases the manufacturer from any responsibility in front of the competent authority.



This product is used in fuel tanks and in hazardous areas for risk of explosion and fire. Subterranean leakages of the fuel tanks may cause serious damages to environment and injury.

DESCRIPTION

The magnetostrictive level transmitters are based on the principle named Wiedemann effect and enable continuous and highly accurate reading of liquids' level.

The XMT level transmitter consists of a microprocessor based electronic circuit placed inside one aluminum case head and a stainless steel shaft containing a wave guide placed inside the tank.

An high frequency electric impulse is transmitted through the electronic device. At the matching point with the magnetic field generated by the permanent magnet placed inside the float, a mechanical impulse is generated thanks to the magnetostrictive torsional strain. The mechanical impulse spreads through the wave guide to the speed of sound up to the sensor in the measuring head. The timing between the transmission of the going impulse and the return impulse define exactly the position of the floats.

Main features	
Measurable product	Diesel, fuel, propane (GPL), water According to the float
Accuracy	± 0,5 mm probe with serial output
Resolution	0,1 mm
Repeatability	± 0,1 mm probe with serial output
Supply	9-30Vcc
Absorption	< 50 mA
Temperature accuracy	± 0,5°C
Temperature measuring range	-45°C ÷ +130°C
Ambience temperature	-20°C ÷ +60°C
INERIS Exd execution	II 1/2 GD Ex d IIA T6 Ex tD A21 IP66/68

Technical features	
Body	Ø 110 mm
Float	Ø 50 mm (other dimensions on demand)
Shaft	Ø 16 mm
Measurable height	500 ÷ 6000 mm

MAIN COMPONENTS

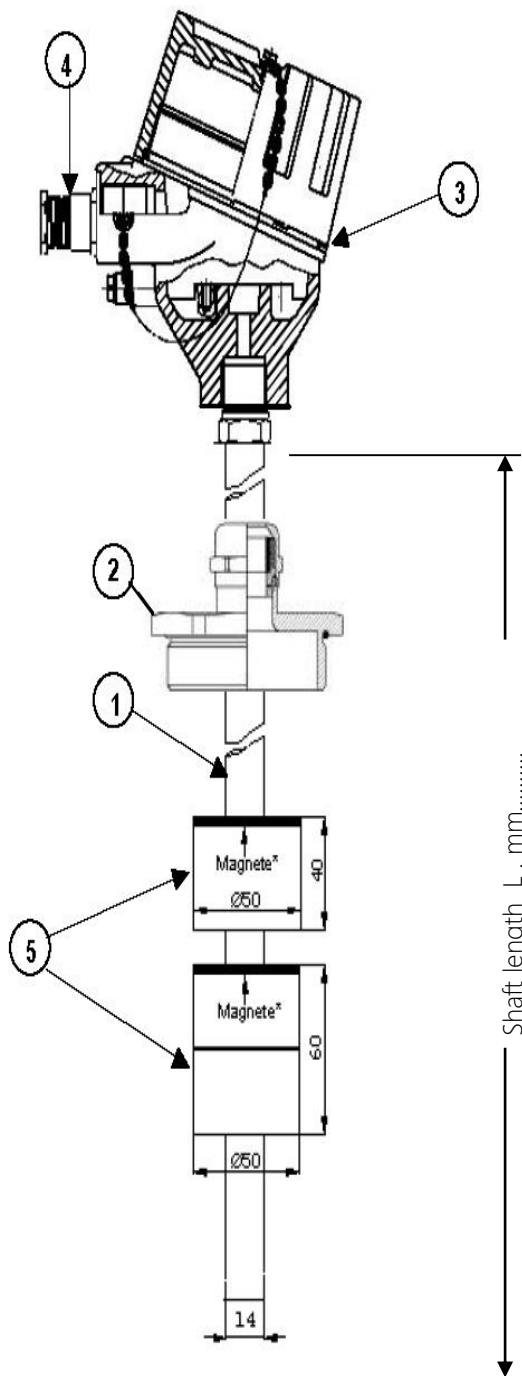

1 Stainless steel shaft AISI 304 - Length from 200 to 6.000 mm

2 Sliding nipple 2" F gas nickel plated brass

3 Die-casted aluminium case IP68

4 Cable gland EExd ½"NPT IP68

5 Floats

Tank standard connection:

Adjustable threaded 3/4"NPT-2"M Gas
Special ones on demand

Electrical connection:

Cable gland EExd ½"NPT IP68

Guide shaft AISI 304:

Diam. 16X2

Case:

Explosion proof IP68 in painted aluminum

Floats:

Foam PVC with closed cells and no-sticking flaps Diam. 50mm
Other materials and dimensions on demand

Temperature:

Liquid: -45°C + 130°C

Head: -25°C + 85°C

ATEX version: -25°C + 60°C

Cable:

Double shielding, twisted, hydrocarbur resistant, 10mm sheath

Power supply:

External supply 9-30 Vdc

Power output:

- RS 485 serial output

- Conversion board from RS485 protocol to 4-20 mA is available (4 wires technology). In this case only the product level will be converted into 4-20mA.

MECHANICAL INSTALLATION



- If mixed with air, the flammable vapors may cause explosion. Hazardous areas may be originated therefore by the presence of gas or vapors.
- Explosions or fire may cause damages, even lethal.
- The magnetostrictive probe can be installed in hazardous areas.

INSTALLATION PROCEDURE

The XMT magnetostrictive level probe is supplied into carton package of one or two pieces. We recommend to check packing integrity.

1. When removing from original packing please pay attention not to bend the stainless steel men-hole reminding that it is an electronic device.
2. The standard version of level probe XMT is supplied with a sliding 2" gas M fitting and the assembled floats enable to easily shift into 2" connection. This makes the probe insertion inside the tank easier, this means that no part of the probe must be disassembled for tank insertion operation.
3. The probe must be placed as much as possible in the center of the tank, it must be far from the product loading.
4. The probe must be assembled by keeping the body as high as possible in order to avoid its flooding.
5. It is recommended to use a 2" riser outside the tank to protect it mechanically.
6. Before introducing the probe inside the tank please check the correct floats positioning and clamping of the shaft end.
7. Carefully unpack the level probe and insert it inside the tank.
8. Insert the probe in the 2" G-F tank gate and make it reach the floor with care then raise it of at least 10mm, this will avoid bending of the shaft in case loading operation make tank deforming.
9. The level probe must be placed in vertical position inside the tank. The shaft inside the tank must not be either folded or blended and must not be subjected to impact or stress.
10. Tighten the adjustable fitting until full clamping on the shaft. Connect probe cable to the plant as described afterwards.
11. Connect sensors as described into "Electrical connection" section.

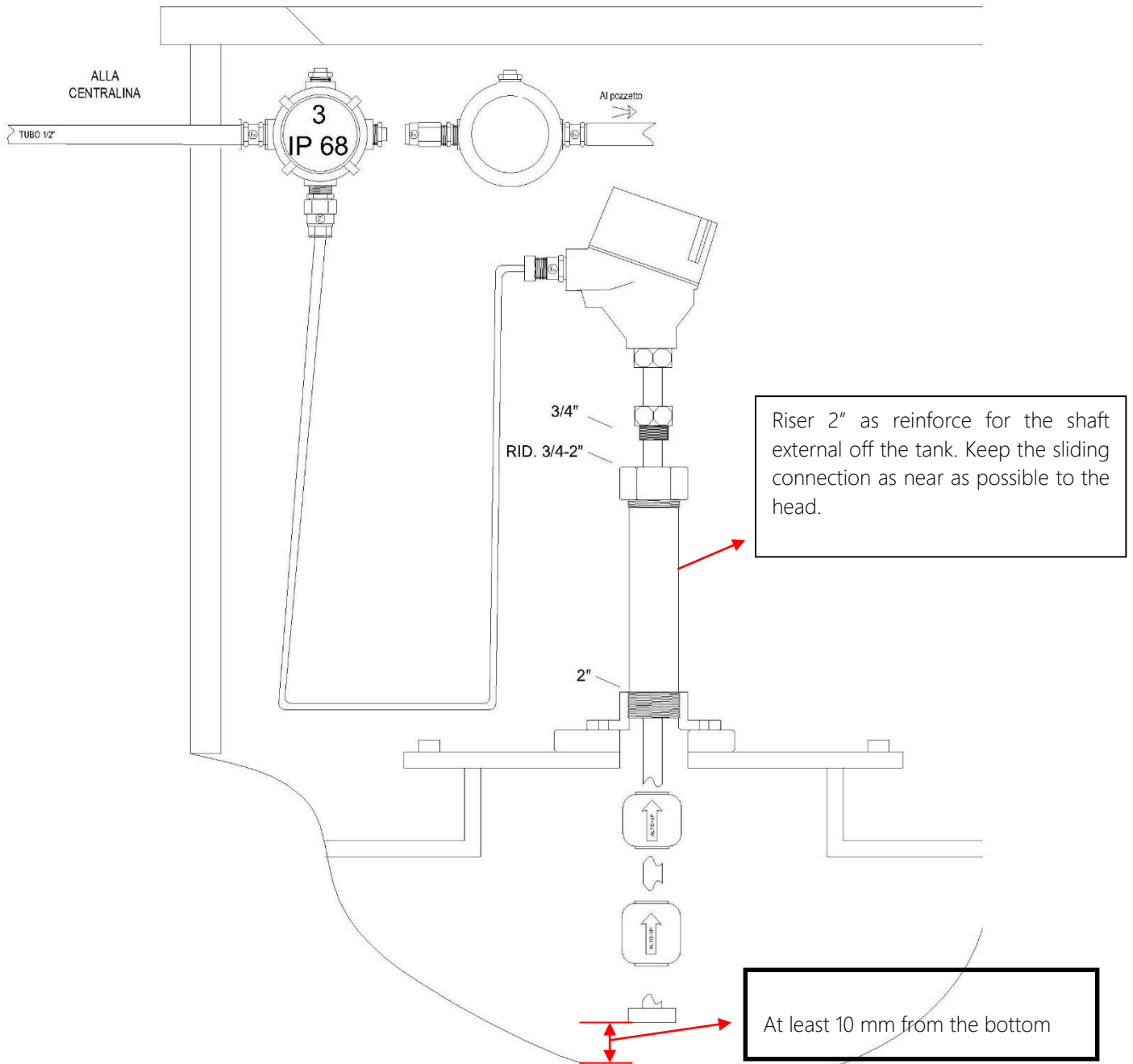

IMPORTANT: if the probe is installed without leaving at least 10mm space from the bottom of the tank and blocked on the top with a sliding connection, any deformation of the tank that occurs will bend the probe compromising the correct functionality.

ELECTRICAL CONNECTION



In case of hydrocarbour vapor use anti-sparks tools

- The installation must be realized by specialized people
- Respect the safety rules
- Read carefully the instruction given into this manual
- The manufacturer is not responsible for any damage and/or supplementary costs due to the missing respect of the supplied instructions.

The probe is supplied with 2 m of cable (1) connected through an ex-proof cable gland (2) to the probe head. This cable must be connected to the back bone using an ex-proof junction box and an ex-proof cable gland.

It is recommended not to cut the cable for an easy extraction of the probe from the tank in case of maintenance.

It is recommended the usage of junction box JB IP68 Exd supplied by Start Italiana under request.

WARNING: the supplied 3 mt cable is moulded inside the probe head with special compound to improve the water proof; its removal compromises the probe functioning, and affect the guarantee and the ATEX certification.

Insert the cable into the console in the locking joint (4).

The cable inside the locking joint must be without external rubber isolation.

Perform the electrical connections into the junction box as shown by the electrical scheme below.

After having tested the good functioning of the system, the locking joint must be filled with resin to avoid the eventual hydrocarbon vapor infiltrations.

Note A

Installation made in compliance with CEI 64-8 and CEI EN 60079-14 standards.

Note B

Use cable compliant with regulation in force in the country of installation.

64-8 Electrical installations with nominal voltage not higher than 1000 Vac and 1500 Vdc. 60079-14 (1998) Classif.CEI 31-33 "Electrical constructions for explosive area for gas presence" Part 14: Electricla installation in ex-proof area for gas presence (excluded mines).

EXTERNAL INSTALLATION SCHEME



- The installation must be realized by specialized people
- Respect the safety rules
- Read carefully the instruction given into this manual
- The manufacturer is not responsible for any damage and/or supplementary costs due to the missing respect of the supplied instructions.

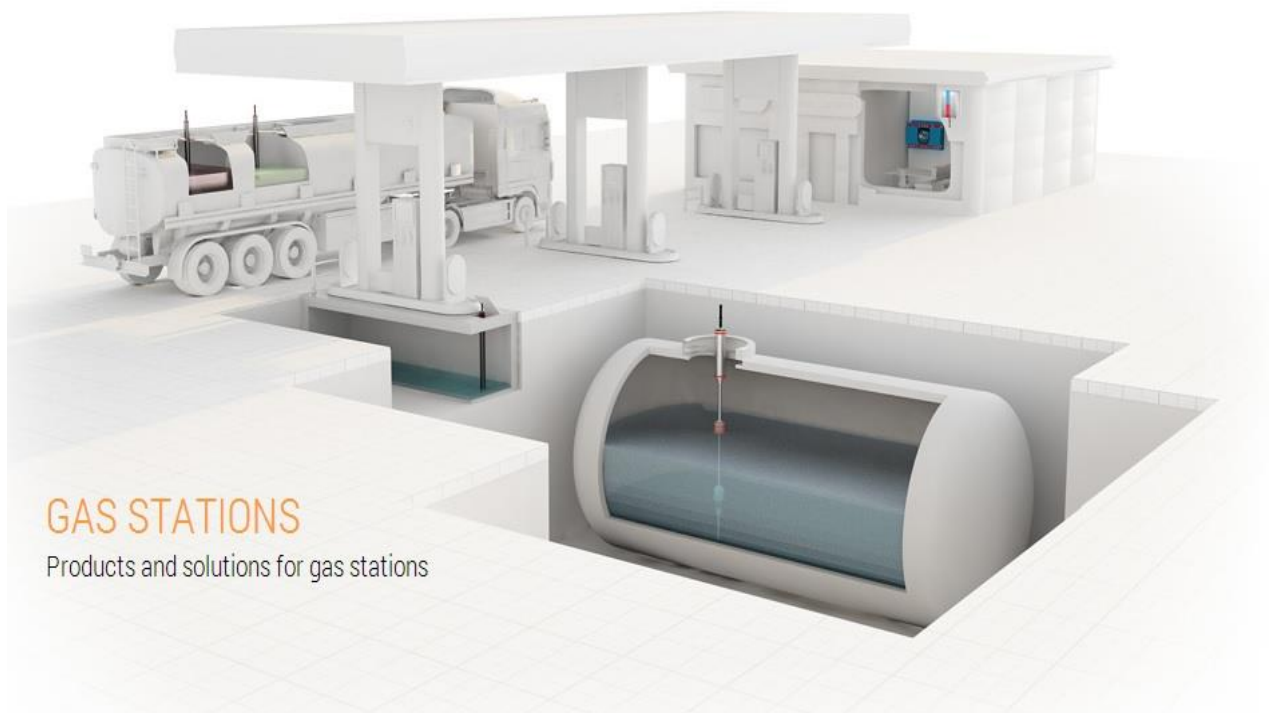

Note A

Installation made in compliance with CEI 64-8 and CEI EN 60079-14 standards.

Note B

Use cable compliant with regulation in force in the country of installation.

64-8 Electrical installations with nominal voltage not higher than 1000 Vac and 1500 Vdc.

60079-14 (1998) Classification CEI 31-33 "Electrical constructions for explosive area for gas presence"
Part 14: Electric installation in ex-proof area for gas presence (excluded mines).

RS485 BUS CONNECTION:

Standard connection scheme of the probes to the bus RS485. Every probe is connected in parallel. If possible please use Start Italiana's IP68 shunt boxes already equipped with connecting terminal.

The 4 wires cable has always red-brown-blue-white colors.
Connect to the terminal the same color type: red-red, white-white, etc.

Shielded cables have all to be connected in parallel as a fifth wire and connected to the earth into the office using a protected ground tap.

Any possible double wall and sump sensors will need the same connection on the same bus.

For connection and programming of the consoles please refer to the manual provided together with the device.

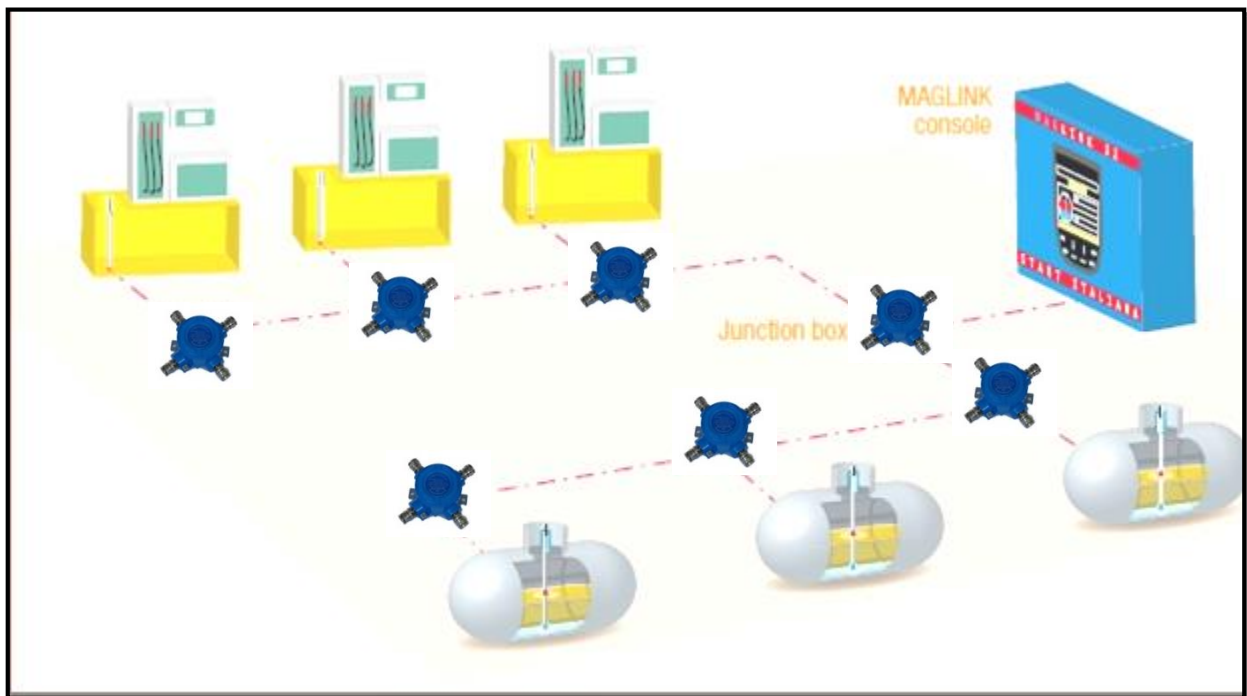

MARKING AND SERIAL NUMBER

Every probe has a unique identification serial number (S.N.) which is also the ID Address of the probe. Take note of the S.N. (ID address), it will be required during system recognition through the set-up Software.

On the cap head there is a metallic label with laser marking which is showing the following information:

MARKING:

Manufacturer: START ITALIANA SRL – 20813 Bovisio Masciago (MB) - Italy
Type: XMT-XCR-XLR-DGM
CE e O.N.: 0722
Group: II ½ GD

EXECUTION:

EEx d IIC T6 IP66/68 T 85° for level probes with /titanium/hastelloy float
EEx d IIA T6 IP66/68 T 85° for level probes with PVC float

LABORATORY: INERIS

A nom: ...
N° certificate:
V max: ...

Signal

S.N. and probe address
T.a.: -20° +60°
Year of manufacture:

FUSION MARKING ON THE CAP HEAD:

Keep cover tight when circuits alive



ELECTRONIC BOARD

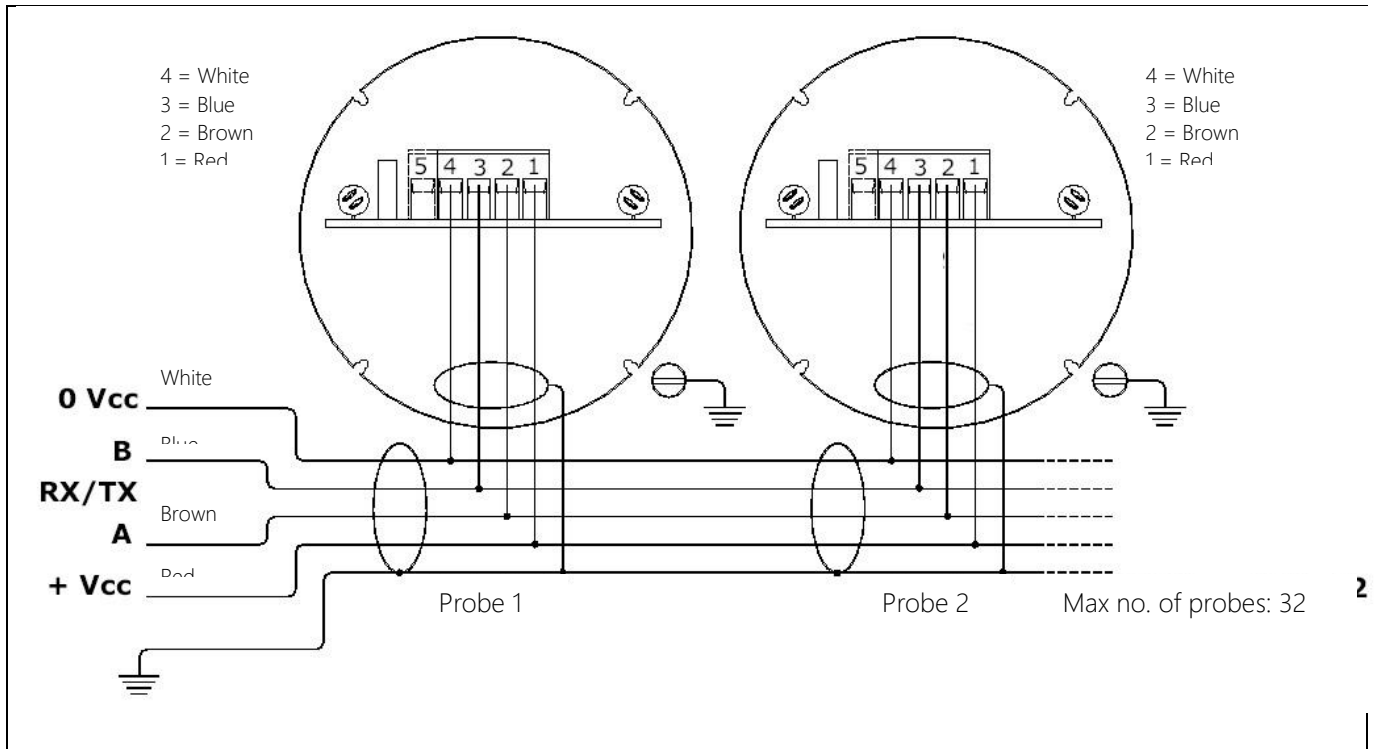

Pos	Component	
1	Power supply 12-30V 2,1	RED
2	RX	BROWN
3	TX	BLUE
4	0 V	WHITE

ATEX CERTIFICATE AND CESI NOTIFICATION



- (2) **Equipment and protective systems intended for use in potentially explosive atmospheres
Directive 94/9/EC**

(1) **EC-TYPE EXAMINATION CERTIFICATE**

- (3) Number of the EC type examination certificate: **INERIS 06ATEX0051**

- (4) Equipment or protective system:

LEVEL TRANSMITTER or SWITCH or DISPLAY TYPE XMT, XCR, XLR or DGM

- (5) Manufacturer: **START ITALIANA srl**
(6) Address: **Via Napoli, 29A
I - 20030 Bovisio Masciago (MI)**

- (7) This equipment or protective system and any other acceptable alternative of this one are described in the annex of this certificate and the descriptive documents quoted in this annex.

- (8) The INERIS, notified body and identified under number 0080, in accordance with article 9 of Council Directive 94/9/EC of the 23rd March 1994, certifies that this equipment or protective system fulfils the Essential of Health and Safety Requirements relating to the design and construction of equipment and protective systems intended for use in potentially explosive atmospheres, described in annex II of the Directive.

The examinations and the tests are consigned in confidential report No P64807/06.

- (9) The respect of the Essential Health and Safety Requirements is ensured by:



- conformity with:

EN 50 014 of June 1997 + Amendments 1 and 2
EN 50 018 of November 2000 + Amendment 1
EN 50 281-1-1 of September 1998 + Amendment 1

- specific solutions adopted by the manufacturer to meet the Essential Health and Safety Requirements described in the descriptive documents.

EC-Type Examination Certificate N° INERIS 06ATEX0051

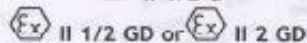
- (10) Sign X, when it is placed following the Number of the EC type examination certificate, indicates that this equipment and protective system is subjected to the special conditions for safe use, mentioned in the annex of this certificate.
- (11) This EC type examination certificate relates only to the design, examination and tests of the specified equipment or protective system in accordance to the directive 94/9/EC. Further requirements of the Directive apply to the manufacturing process and supply of this equipment or protective system, these are not covered by this certificate.
- (12) The marking of the equipment or the protective system will have to contain:

 II 1/2 G
 II 1/2 GD or  II 2 GD

EEx d IIB T6 or EEx d IIC T6
EEx d IIB T6 or EEx d IIC T6 T85 °C IP66/68

Verneuil-en-Halatte, 2006 11 15



C. PETITFRERE

Project Manager at the ATEX
Equipment Certification Laboratory

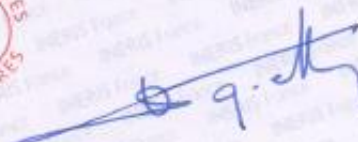

Director of the Certifying Body,
By delegation
B. PIQUETTE
Deputy Manager of Certification

EC-Type Examination Certificate N° INERIS 06ATEX0051

(13)

ANNEX

(14)

EC TYPE EXAMINATION CERTIFICATE N° INERIS 06ATEX0051

(15)

DESCRIPTION OF THE EQUIPMENT OR THE PROTECTIVE SYSTEM

This apparatus, intended with different types, consists in a tube screwed on one of the following flameproof enclosures :

- Type XD-AD, XD-Adwin or XD-ADH covered by the EC type examination certificate FTZU 03ATEX0074U, code EEx d IIC.
- Type XD-I or XD-Iwin covered by the EC type examination certificate FTZU 03ATEX0207U, code EEx d IIC;
- Type XD-ID100 or XD-ID100win covered by the EC type examination certificate FTZU 04TEX0332U code EEx d IIC.

One version for display, type DGM, is intended without tube.

The tube fitted with the metallic or spansil NBR float is located in Zone 0.

The enclosure gets the protection degrees IP66/68 according to the European standard EN 60 529, the verification of the protection degree IPX8 corresponds to an immersion under 1 meter of water during one hour.

PARAMETERS RELATING TO THE SAFETY**Transmitter type XMT and Display type DGM :**

Supply voltage : 9 to 30 V (dc)
Current : 15 to 110 mA
Maximum power dissipated : 600 mW

Transmitter type XCR :

Supply voltage : 12 to 30 V (dc)
Maximum power dissipated : 600 mW

Switch type XLR :

Supply voltage : 220 to 400 V (ac or dc)
Current : 0.5 to 3 A

EC-Type Examination Certificate N° INERIS 06ATEX0051

MARKING

Marking has to be readable and indelible; it has to include the following indications:

A- Transmitter or switch with spansil NBR float :

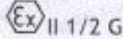
- START ITALIANA srl
- I - 20030 Bovisio Masciago (MI)
- (*)
- INERIS 06ATEX0051
- (Serial number)
- (Year of construction)
-  II 1/2 G
- EEx d IIB T6
- Tamb : -20°C to 60°C
- DO NOT OPEN WHEN ENERGIZED

(*) One of the following types : XMT, XCR or XLR

B- Transmitter or switch with metallic float :

- START ITALIANA srl
- I - 20030 Bovisio Masciago (MI)
- (*)
- INERIS 06ATEX0051
- (Serial number)
- (Year of construction)
-  II 1/2 GD
- EEx d IIC T6
- T85°C IP66/68
- Tamb : -20°C to 60°C
- DO NOT OPEN WHEN ENERGIZED

(*) One of the following types : XMT, XCR or XLR

C- Display DGM :

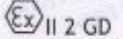
- START ITALIANA srl
- I - 20030 Bovisio Masciago (MI)
- DGM
- INERIS 06ATEX0051
- (Serial number)
- (Year of construction)
-  II 2 GD
- EEx d IIC T6
- T85°C IP66/68
- Tamb : -20°C to 60°C
- DO NOT OPEN WHEN ENERGIZED

Marking may be carried out in the language of the country of use.

The protective system or equipment has also to carry the marking normally stipulated by its construction standards.

EC-Type Examination Certificate N° INERIS 06ATEX0051

ROUTINE EXAMINATIONS AND TESTS

Each equipment, except the display type DGM, defined above have to successfully passed the following individual tests before delivery :

- In accordance with clause 16.1 of the EN 50 018 standard, an overpressure test of a period comprised between 10 and 60 seconds under 30.8 bar.

(16) DESCRIPTIVE DOCUMENTS

The descriptive documents quoted hereafter constitute the technical documentation of the equipment, subject of this certificate.

- Certification file n° A4-015 rev.0 of 2006.07.03 signed on 2006.07.03 included 7 items.

(17) SPECIAL CONDITIONS FOR SAFE USE

The conditions are stipulated on the instruction.

(18) ESSENTIAL SAFETY AND HEALTH REQUIREMENTS

The respect of the Essential Health and Safety Requirements is ensured by:

- Conformity to the European standards EN 50 014, EN 50 018 and EN 50 281-1-1.
- All provisions adopted by the manufacturer and defined in the descriptive documents.

Addition No 01 to the EC-type examination certificate INERIS 06ATEX0051

ADDITION

- (3) **INERIS 06ATEX0051/01**
- (4) **LEVEL TRANSMITTEUR or SWITCH or DISPLAY TYPE XMT, XCR, XLR or DGM**
- (5) **Made by START ITALIANA srl**
- (15) **PURPOSE OF THE ADDITION**
- Application of new standards EN 60079-0 : 2006, EN 60079-1 : 2004, EN 61241-0 : 2006 and EN 61241-1 : 2004.
 - Use of a new float in PVC.
 - Adjonction of a new boxes type XD-JBA, XD-JBAwin, XD-JBB and XD-JBBwin covered by the EC type examination certificate FTZU 07ATEX0134U, code Ex d tD IIC.

PARAMETERS RELATING TO THE SAFETY

The parameters relating to the safety are unchanged.

MARKING

The marking is modified as follows:

A- Transmitter or switch with spansil NBR float :

START ITALIANA
I - 20030 Bovisio Masciago (MI)
(*)
INERIS 06ATEX0051
(Serial number)
(Year of construction)
 II 1/2 GD
Ex d IIB T6
Ex tD A21 IP66/68 T85°C
T_{amb} : -20°C to 60°C

WARNING : DO NOT OPEN WHEN ENERGIZED

(*) One of the following types : XMT, XCR or XLR

Addition No 01 to the EC-type examination certificate INERIS 06ATEX0051

B- Transmitter or switch with metallic float :

START ITALIANA

I - 20030 Bovisio Masciago (MI)

(*)

INERIS 06ATEX0051

(Serial number)

(Year of construction)

 II 1/2 GD

Ex d IIC T6

Ex tD A21 IP66/68 T85°C

T_{amb} : -20°C to 60°C

WARNING : DO NOT OPEN WHEN ENERGIZED

(*) One of the following types : XMT, XCR or XLR

C- Transmitter or switch with spansil PVC float :

START ITALIANA

I - 20030 Bovisio Masciago (MI)

(*)

INERIS 06ATEX0051

(Serial number)

(Year of construction)

 II 1/2 GD

Ex d IIA T6

Ex tD A21 IP66/68 T85°C

T_{amb} : -20°C to 60°C

WARNING : DO NOT OPEN WHEN ENERGIZED

(*) One of the following types : XMT, XCR or XLR

D- Display DGM :

START ITALIANA

I - 20030 Bovisio Masciago (MI)

DGM

INERIS 06ATEX0051

(Serial number)

(Year of construction)

 II 2 GD

Ex d IIC T6

Ex tD A21 IP66/68 T85°C

T_{amb} : -20°C to 60°C

WARNING : DO NOT OPEN WHEN ENERGIZED

Marking may be carried out in the language of the country of use.

The protective system or equipment has also to carry the marking normally stipulated by its construction standards.

- ⊕ Addition No 01 to the EC-type examination certificate INERIS 06ATEX0051

ROUTINE EXAMINATIONS AND TESTS

The routine examinations and tests are modified as follows :

Each equipment defined above, except the display type DGM, have to successfully passed the following individual tests before delivery in accordance with clause 16.1 of the EN 60079-1 standard, an overpressure test of a period comprised between 10 and 60 seconds under 30.8 bar.

(16) DESCRIPTIVE DOCUMENTS

The descriptive document quoted hereafter constitutes the technical documentation describing the modification of the equipment, subject of this present addition.

Certification file n° A4-015 rev.1 of 2007.03.06 (8 rubrics)

signed on 2008.02.18

(17) SPECIAL CONDITIONS FOR SAFE USE

None.

(18) ESSENTIAL SAFETY AND HEALTH REQUIREMENTS

The respect of the Essential Health and Safety Requirements is completed as follows:

- Conformity to the standards EN 60079-0:2006, EN 60079-1:2004, EN 61241-0:2006 and EN 61241-1:2004.
- All provisions adopted by the manufacturer and defined in the descriptive documents.

Verneuil-en-Halatte, 2008 03 06

S. MAUGER
Project Manager at the ATEX
Equipment Evaluation Laboratory



Director of the Certifying Body,
By delegation
T. HOUËIX
Certification Officer
Certification Division

Addition No 02 to the EC-type examination certificate INERIS 06ATEX0051

ADDITION(3) **INERIS 06ATEX0051/02**(4) **LEVEL TRANSMITTER or SWITCH or DISPLAY TYPE XMT, XCR, XLR or DGM**(5) **Made by START ITALIANA S.r.l**(15) **PURPOSE OF THE ADDITION**

Adjonction of a new boxes for DGM version type LIMATHERM XD-120 and LIMATHERM XD-JB-85 covered by the EC type examination certificate FTZU 08ATEX0181U and FTZU 05ATEX0262U.

PARAMETERS RELATING TO THE SAFETY

The parameters relating to the safety are unchanged.

MARKING

The marking is unchanged.

ROUTINE EXAMINATIONS AND TESTS

The routine examinations and tests are unchanged.

(16) **DESCRIPTIVE DOCUMENTS**

The descriptive document quoted hereafter constitutes the technical documentation describing the modification of the equipment, subject of this present addition.

- Certification file n° A4-015 rev.0 of 2010.01.18 (5 rubrics) signed on 2010.01.18

(17) **SPECIAL CONDITIONS FOR SAFE USE**

None.

Addition No 02 to the EC-type examination certificate INERIS 06ATEX0051

(18) ESSENTIAL SAFETY AND HEALTH REQUIREMENTS

The respect of the Essential Health and Safety Requirements is unchanged.

Verneuil-en-Halatte, 2010 04 02



Director of the Certifying Body,
By delegation
T. HOUeix
Certification Officer
Certification Division

CESI



CESI S.p.A.
Via Rubattino 54
I-20134 Milano - Italy
Tel: +39 02 21251
Fax: +39 02 21255440
e-mail: info@cesi.it
www.cesi.it

Schema di certificazione

CESI-ATEX



PRD N. 018B
Membro degli Accordi di Mutuo Riconoscimento EA, IAF e ILAC
Signatory of EA, IAF and ILAC Mutual Recognition Agreements

ATEX E N.021-1-1

NOTIFICATION



[1] **PRODUCTION QUALITY ASSURANCE NOTIFICATION**

[2] **Equipment or Protective System or Component intended for use in potentially explosive atmospheres Directive 94/9/EC**

[3] Notification number:
CESI 06 ATEX 031 Q

[4] Equipment or component type: Transmitters and level switches
Capacitive sensors for continuous liquid level measurement and discriminative function for different Terminal boxes
Magnetostrictive level sensors
Galvanically isolated barriers
Flameproof enclosures "d"
Intrinsic safety "i"
Encapsulation "m"
Dust ignition protection "tD"
Mechanical protection by constructional safety "c"
Dust ignition protection "t"
Pressurization "p"

Protection concepts:

[5] Applicant: START Italiana S.r.l.
via Pola, 6
20813 Bovisio Masciago - MB

[6] Manufacturer: START Italiana S.r.l.
via Pola, 6
20813 Bovisio Masciago - MB

[7] CESI, notified body n. 0722 in accordance with Article 9 of the Council Directive 94/9/EC of 23 March 1994, notifies to the applicant that the actual manufacturer has a production quality system which complies to Annex IV of the Directive.

[8] This notification is based on audit report n. EX-B5006989 issued the 9/03/2015.

This notification can be withdrawn if the manufacturer no longer satisfies the requirement of Annex IV.

Results of periodical re-assessment of the quality system are a part of this notification.

[9] This notification is **valid until 17/03/2018** and can be withdrawn if the Manufacturer does not satisfy the production quality assurance re-assessment.

[10] According to Article 10 [1] of the Directive 94/9/EC the CE marking shall be followed by the identification n. 0722 identifying the notified body involved in the production control stage.

This notification may only be reproduced in its entirety and without any change.

Date of 1st issue
17th March 2006

Date of renewal
17th March 2015

Translation issued 17th March 2015

Prepared
Sergio G. Giugno

Page 1/1

Verified
Mirko Balaž

Approved
Roberto Piccin

CESI S.p.A.
Testing & Certification Division



START *italiana* S.r.l.
Via Pola, 6
20813 Bovisio Masciago MB
Tel: +39 0362 15.81.465
Fax: +39 0362 15.81.464