

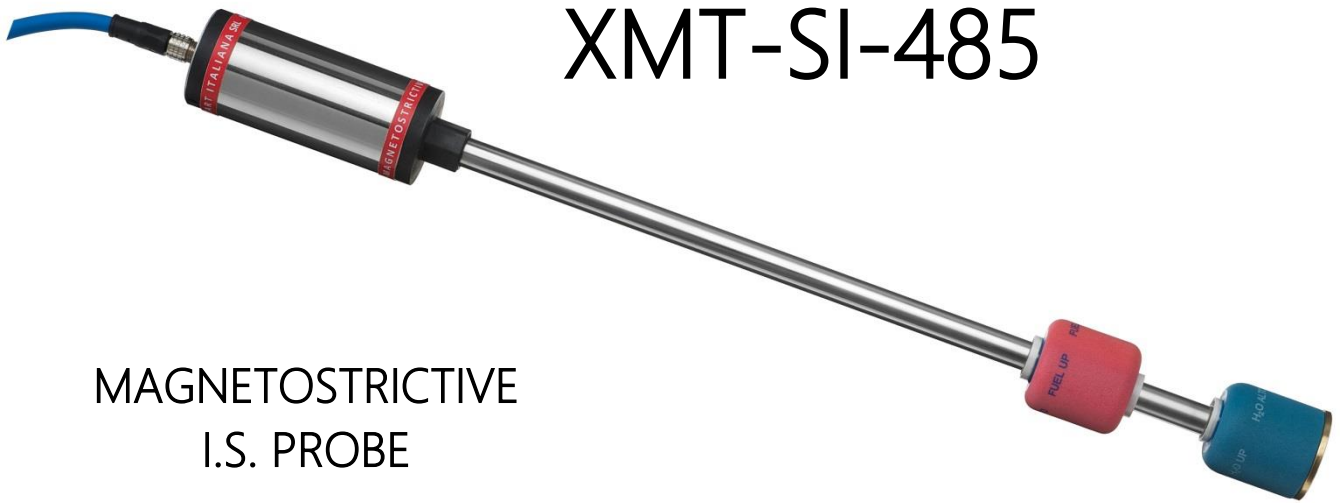

INSTALLATION MANUAL



XMT-SI-485

MAGNETOSTRICTIVE
I.S. PROBE



XMT-SI-RF

WIRELESS
I.S. PROBE

ALSO AVAILABLE BLACK SEAL VERSION

INDEX

INDEX.....	2
REVISION INDEX.....	2
INTRODUCTION.....	3
GENERAL WARNINGS.....	3
GENERAL INFORMATION.....	4
TECHNICAL CHARACTERISTICS XMT-SI.....	5
WIRING OF THE CONNECTOR.....	6
PRODUCT LABEL.....	7
MECHANICAL INSTALLATION XMT-SI.....	8
EXAMPLE OF RISER PREPARATION FOR RF PROBES.....	10
ELECTRICAL CONNECTION.....	13
XMT-SI-485 HOUSING OPENING AND CLOSURE.....	14
JUMPER SETTING.....	14
MODEL XMT-SI-RF.....	15
DIP-SWITCH PROGRAMMATION.....	15
MODEL XMT-SI-485.....	17
DIP-SWITCH PROGRAMMATION.....	17
TRANSMISSION PROTOCOL.....	17
XMT-SI-485-LOG PROBE WITH MEMORY AND DATA LOGGER FUNCTIONALITY.....	19
DATA LOGGER PROTOCOL.....	19
BLACK SEAL VERSION.....	22
ATEX CERTIFICATION AND NOTIFICATION.....	23

REVISION INDEX

DATA	REVISION NUMBER	DESCRIPTION	Versione Firmware
01-09-2014	05	GENERAL REVISION	
23-09-2014	06	BLACK SEAL VERSION ADDED	
30-04-2015	07	GENERAL UPDATES	

	<p>This product complies with EU Directive 2012/19/UE.</p> <p>The crossed-bin symbol fixed on the device indicates that the product, at the end of its useful life, should be disposed of separately from household waste, must be taken to a collection point for electrical and electronic equipment.</p>
---	--

Nota: Start Italiana Srl, in respect of its quality duty may modify its production and data shown into this manual. This manual cannot be copied, neither partially, without authorization.

INTRODUCTION

This manual gives all the installation and use instructions for XMT-SI level probes family.

GENERAL WARNINGS

- Before the installation and use of the equipment please carefully read the instructions given into this manual.
- The manufacturer is not responsible of any possible operation not mentioned into this manual.
- Any failure or faulty operation would occur to the equipment, please refer to the authorized personnel for maintenance or directly to the manufacturer.
- The manufacturer refuses all responsibility for any eventual injury and/or damage to things caused to the non-observance of the safety regulations.
- The assigned personnel is required to know all the safety regulations relative to the hereby described equipment.
- Any doubt may occur about the functioning of the equipment please refer to the authorized personnel for maintenance or directly to the manufacturer.
- Tampering releases the manufacturer from any responsibility in front of the competent authority.



- This product is used in fuel tanks and in hazardous areas for risk of explosion and fire. Subterranean leakages of the fuel tanks may cause serious damages to environment and injury.
- If mixed with air, the flammable vapors may cause explosion. Hazardous areas may be originated therefore by the presence of gas or vapors.
- Explosions or fire may cause damages, even lethal.
- The magnetostrictive probe can be installed in hazardous areas.

GENERAL INFORMATION

The magnetostrictive level transmitters are based on the principle named Wiedemann effect and enable continuous and highly accurate reading of liquid's level.

The XMT-SI level transmitter consists of a microprocessor based electronic circuit placed inside one aluminium case head and a stainless steel shaft containing a wave guide placed inside the tank.

An high frequency electric impulse is transmitted through the electronic device. In the matching point with the magnetic field generated by the permanent magnet placed inside the float, a mechanic impulse is generated thanks to the magnetostrictive torsional strain. The mechanic impulse spreads through the wave guide to the speed of sound up to the sensor placed in the measuring head. The timing between the transmission of the going impulse and the return impulse exactly defines the position of the floats.

XMT-SI family are high precision measure instrumentation which are suitable to measure product level, water level and temperature in various type of underground and above ground tank, also placed in hazardous areas.

The XMT-SI family is intrinsically safe certified for 0 Zone and through an intrinsically safety barrier can be connected to console or PC positioned in a safety zone for having a complete control of the tank.

The following models are available:

XMT-SI-485 transmits data on the 485 bus. It can be configured for polling mode or push mode functioning based on the needing. It is externally powered by the communication bus.

XMT-SI-RF transmits data using a radiofrequency transmission with variable frequency depending on the level changes inside the tank. It is powered by a lithium battery positioned inside the probe and certified also for intrinsically safety. In order to grant the intrinsically safety of the transmitter, the battery must be replaced only by another one supplied by Start Italiana.

XMT-SI-TTL transmits data using a TTL interface for OEM applications. The associated instrument must be certified in case it is necessary to install the product in a certified zone.

XMT-SI-485-LOG transmits data on a 485 bus. It is configured for functioning in polling mode. Normally it is powered externally using a communication bus. If the external power is disconnected, automatically a battery placed inside allows to keep the probe working and stores the level changes in a non-volatile memory for subsequent download of the data possible on recovery of the main supply.

TECHNICAL CHARACTERISTICS XMT-SI

Four types of interface are available:

RS 485 serial door for multipoint connection

- Power supply 12 VDC through an intrinsically safe barrier.
- Consumption <15 mA @ 12 Vdc normal functioning
- Consumption < 200 uA @12 Vdc in sleep mode functioning
- Connection cable: hydrocarbons resistant, suitable for underground pose with insulation 0,6-1KV, 2 shielded and twisted pairs, section of the power cable pair of at least 1mm².
- Type of cable supplied by Start Italiana: LiYstCYY INSULATION LEVEL 4 (0,6/1KV) - (2x0.25mm²) + 2x1.00mm² CEI 20-22II IEC 60332-3A ENI 00.181.00
- Maximum transmission distance: up to 2 Km based on standard of RS485 interface.

RF interface:

- Internal power supply through an intrinsically safe battery 3.6V, 16Ah
- Low frequency transmission to a receiver located in a safety zone.
- Consumption <15 mA @ 12 Vdc normal functioning
- Consumption < 200 uA @12 Vdc in sleep mode functioning

TTL Interface for OEM applications:

- Power supply 5Vmax, 100mA max from certified external device
- Serial transmission TTL levels
- Maximum distance:3 mt, compatible with TTL signals

RS485-LOG serial door for multipoint connection with internal battery for storage of data in case of missing external power supply or polling

- Power supply 12 VDC through an intrinsically safe barrier.
- Consumption <15 mA @ 12 Vdc normal functioning
- Consumption < 200 uA @12 Vdc in sleep mode functioning
- Internal power supply through an intrinsically safe battery 3.6V, 16Ah
- Connection cable: hydrocarbons resistant, suitable for underground pose with insulation 0,6-1KV, 2 shielded and twisted pairs, section of the power cable pair of at least 1mm².
- Type of cable supplied by Start Italiana: LiYstCYY INSULATION LEVEL 4 (0,6/1KV) - (2x0.25mm²) + 2x1.00mm² CEI 20-22II IEC 60332-3A ENI 00.181.00
- Maximum transmission distance: up to 2 Km based on standard of RS485 interface.

For all the types the measurement characteristics are:

- Electronics based on a Microprocessor
- Support telediagnosics and telemaintenance
- Possibility to configure remotely the functional parameters
- In case of maintenance the internal part of the sensor (wave guide) can be removed without degas the tank, especially useful for LPG applications where the tanks are in pressure.
- Tank connection:
 - Not needed if probe is inserted into a riser with internal diameter 2"
 - 2" sliding connection as standard.
 - Other type of optional connections under request (nipped fixed, flanged, ...)
- Stainless steel case, IP68.
- Probe shaft Stainless Steel AISI 304 / 316

- Measurement range: from 200 mm. to 12.500 mm.
- Maximum mechanical length: 13.000 mm.
- Data transmitted:
 - Product level in 0.01 mm
 - Water level in 0.01 mm
 - Medium temperature detected through digital temperature sensor placed along the probe shaft (max 5)
- Measurement accuracy: +/- 0,5 mm.
- Measurement resolution: +/- 0,05 mm.
- Temperature accuracy: +/- 0,2°C
- Approvals :
 - OIML-R85 for fixed applications
 - OIML-R80 per mobile applications

WIRING OF THE CONNECTOR

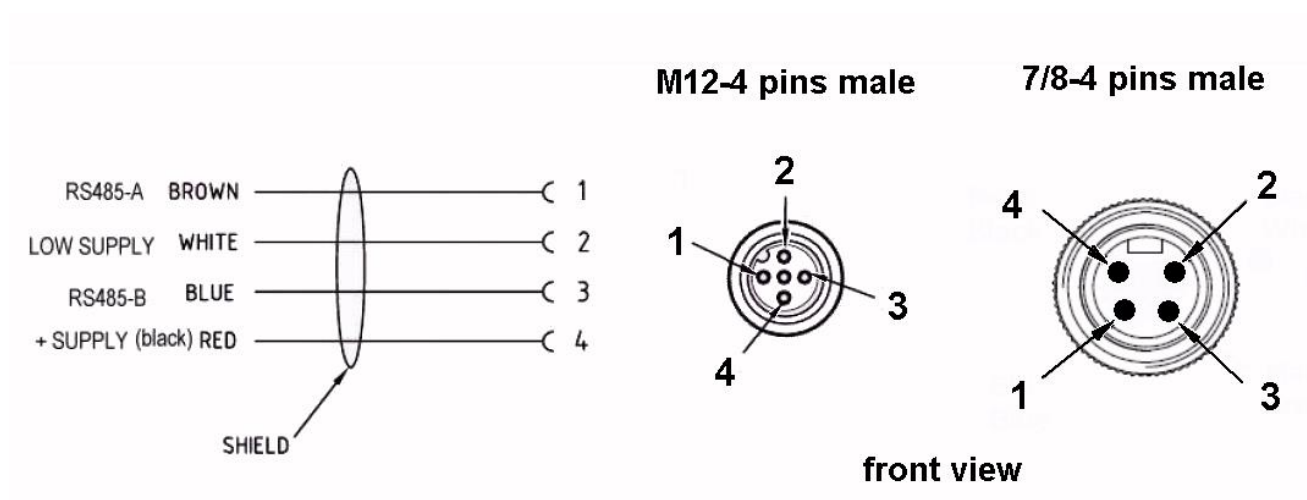

T= - 40°C + 85°C

U_i = 16V I_i = 125mA

C_i = trascurabile/negligibile

L_i = trascurabile/negligibile

The serial number is unique and corresponds to the probe address for the consequent configuration into the control electronics.

PRODUCT LABEL

XMT-SI-485

START ITALIANA S.r.l. - Italy

Via Pola, 6 - 20813 Bovisio Masciago (MB)

 0722 CEC 09 ATEX 131 rev.3

 I 1G Ex ia IIB T4 Ga

 I 1D Ex t IIIC T135°C Da IP66/68

Tipo/Type: XMT-SI-485

Anno/Year: (20)XX

S.N.: XXXXX

T= - 40°C + 85°C

Ui = 16V li = 125mA

Ci = trascurabile/negligible

The serial number is unique and corresponds to the probe address for the consequent configuration into the control electronics.

XMT-SI-RF

START ITALIANA S.r.l. - Italy

Via Pola, 6 - 20813 Bovisio Masciago (MB)

 0722 CEC 09 ATEX 131 rev.3

 I 1G Ex ia IIB T4 Ga

 I 1D Ex t IIIC T135°C Da IP66/68

Tipo/Type: XMT-SI-RF

Anno/Year: (20)XX

S.N.: XXXXX

T= - 40°C + 85°C

Lithium battery inside

The serial number is unique and corresponds to the probe address for the consequent configuration into the control electronics.

MECHANICAL INSTALLATION XMT-SI

The XMT-SI magnetostrictive level probe is supplied into carton packages for station, packed singularly or up to 7 pieces. We recommend to check packing integrity.

When removing the original packing please pay attention not to bend the stainless steel men-hole reminding that it is an electronic device.

The standard version of level probe XMT-SI is supplied with a sliding 2" gas M fitting or without fitting in case of installation inside a protection riser.

The sliding 2" gas M fitting and the assembled floats enable to easily shift into 2" connection. This makes the probe insertion inside the tank easier, and it means that no part of the probe must be disassembled.

The probe must be placed as much as possible in the center of the tank, in vertical position, and it must be far from the product loading. The shaft inside the tank must not be either folded or blended and must not be subjected to impact or stress.

The probe must be mounted keeping the head as much high as possible to avoid its flooding. Insert the probe in the 2" G-F tank gate and make it reach the floor with care then raise it of at least 10mm, this will avoid bending of the shaft in case loading operation make tank deforming.

Before introducing the probe inside the tank please check the correct floats positioning and clamping of the plastic shaft end cap. In order to allow to the floats to identify correctly water and fuel levels, it is important to verify that the plastic shaft end cap has been clamped on the shaft on the correct side.

Connect probe cable to the plant as described afterwards.

Connect sensors as described into the "Electrical connection" section.

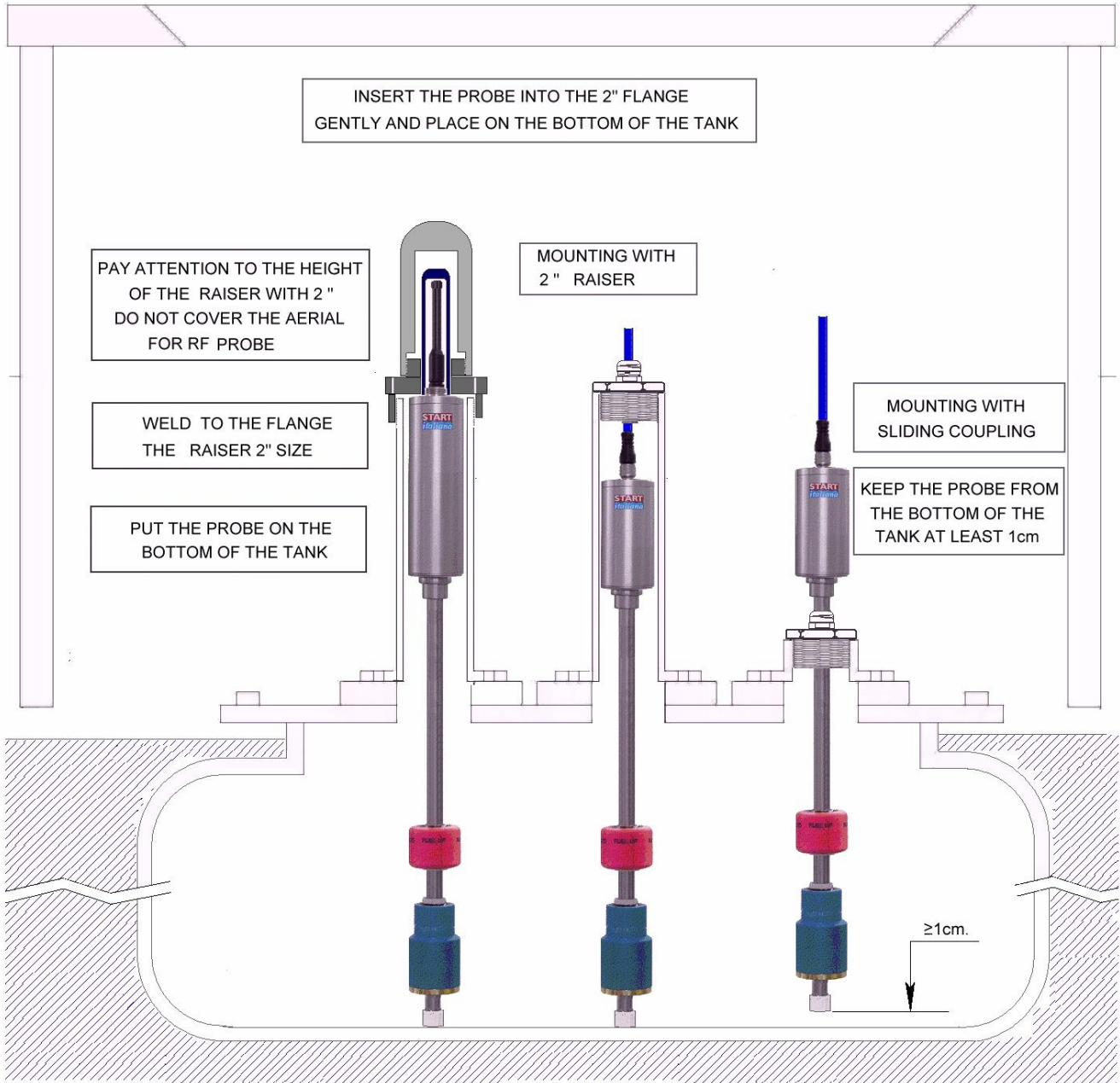

EXAMPLE OF RISER PREPARATION FOR RF PROBES

- Use galvanized pipe with internal diameter of mm. 52 (weld pipe);
- Cut the correct size in order that once screwed the riser goes to cover the probe head leaving completely free the transmitting-receiving antenna;
- Seal the thread at the side flange with hemp and sealant to ensure tightness of the tank;

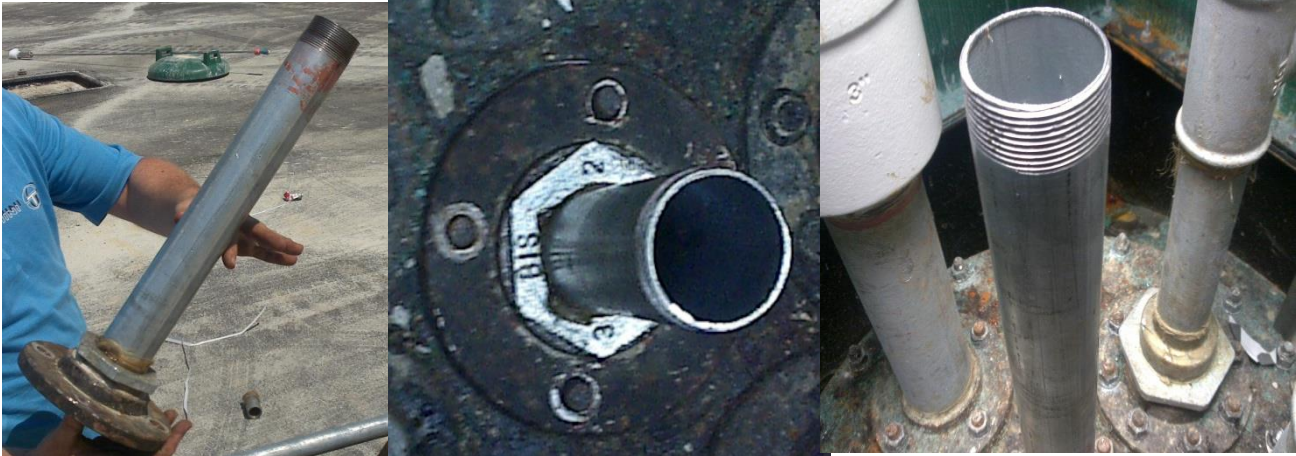

- After installation of the riser, place carefully the wireless probe into the tank;



- After positioning into the tank, tighten the PA antenna protection supplied with the probe;



- Finally tighten the PA 2" protection supplied with the wireless probe applying a sealant product (Loctite, etc.) between the male riser and female, paying attention not to force too much the screwing.

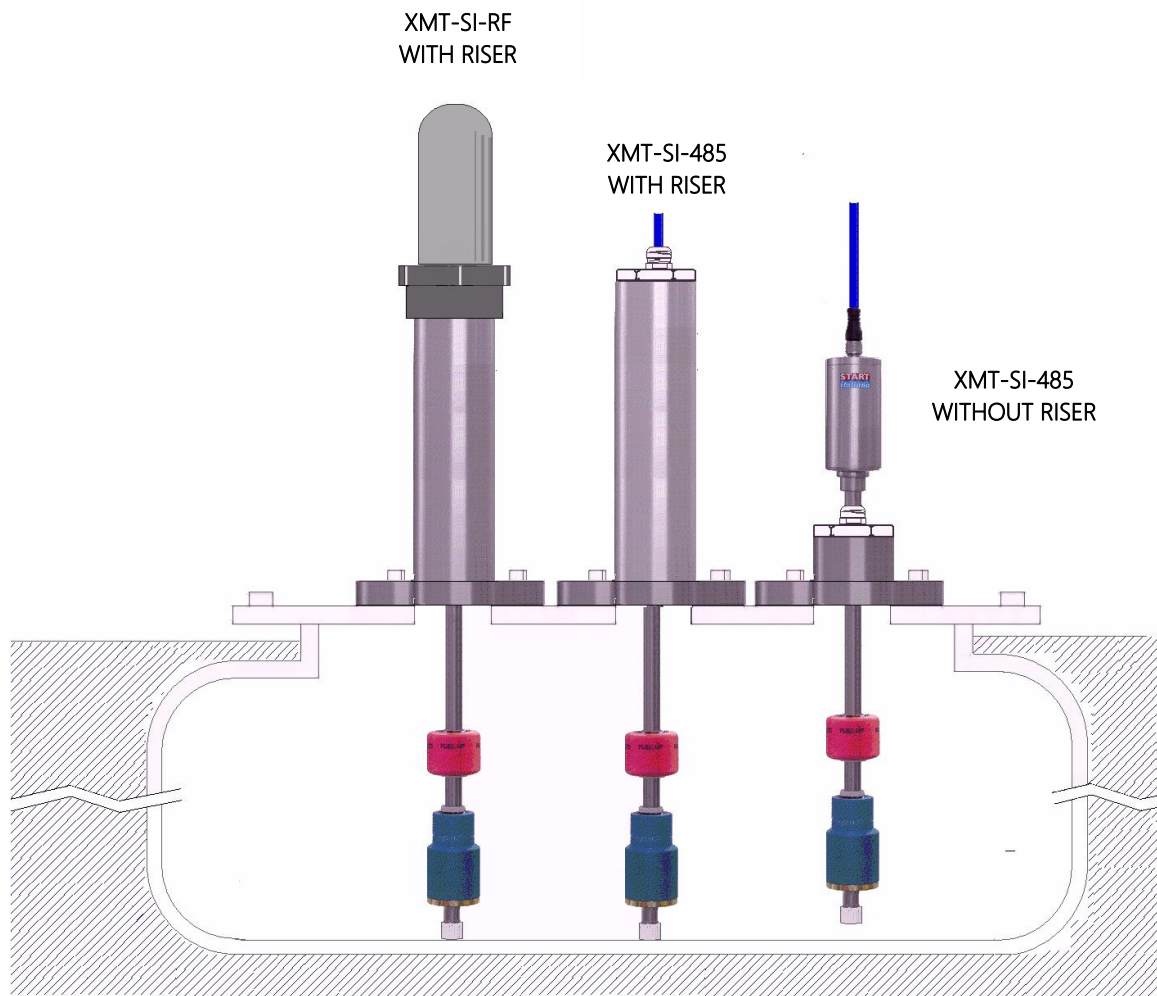

Please follow the above procedures if probes are wired. The only difference is that the length of the riser must cover the total length of the probe, and a cap with a cable gland must be screwed to allow the exit of the connection cable.

Please refer to RF receiver technical manual supplied with the product for the installation procedure.

ELECTRICAL CONNECTION



In case of hydrocarbon vapor please use anti-sparks tools.

- The installation must be realized by specialized people
- Respect the safety rules
- Read carefully the instructions provided into this manual
- The manufacturer is not responsible for any damage and/or supplementary costs due to the missing respect of the supplied instructions.

The probe is supplied with 2 meters of cable connected through M12 or 7/8 connector to the probe head. This cable must be connected to the back bone using a junction box.

It is recommended to use a junction box IP68 for intrinsically safety connection supplied by Start Italiana under request.

In a typical electrical connection all the probes are connected in parallel. Normally all the bus connections must be cascading to grant certain transmission distances. In case of service stations distances are extremely reduced, branches no longer than 50 meters, and in this case it is acceptable to have a star type wiring.

Please use if possible Start Italiana junction boxes IP68 and complete of internal terminal box.

The 4 wire connection cable has always red (or black)-brown-blue and white colors.

Connect to the terminal box the same color type: red-red, white-white etc. Panel cables have all to be connected in parallel as a fifth wire and connected to the earth into the office using a protected ground tap which must not be shared with those of motors or power systems.

For connection and programming of the consoles please refer to the manual provided together with every device.

The installation must be done in compliance with CEI 64-8 and EN 60079-14 standards.

Use cable compliant with regulation in force in the country of installation.

CEI 64-8 Electrical installations with nominal voltage not higher than 1000Vac and 1500Vdc

EN 60079-14 Classif.CEI 31-33 "Electrical constructions for explosive area for gas presence".

Part 14: Electrical installation in ex-proof area for gas presence (excluded mines).

XMT-SI-485 HOUSING OPENING AND CLOSURE

*IMPORTANT: TOP AND BOTTOM HOUSING CAPS CANNOT BE UNSCREWED.
PLEASE PAY ATTENTION NOT TO LOOSE OR DAMAGE ANY OF THE COMPONENTS DISMOUNTED.*

1. Remove the black Viton caps which cover the screws fixed on the bottom cap of the housing (Picture 1)
2. Remove the brass screws
3. Pay attention not to lose the O-ring (Picture 2)
4. Extract the housing keeping the top connector, take care about the electronics inside the housing
5. Once the Jumper setting has been completed as explained below, assemble again the housing, paying attention to fix correctly all the components that have been previously dismantled.



Picture 1



Picture 2



Picture 3

JUMPER SETTING

The meaning of the Jumpers is listed below. Jumpers are read during startup of the device. Every change made when the device is switched on won't be considered. It is necessary to switch off and restart again the device so that the changes are applied.

Jumper nr	INSERTED	REMOVED
1	1 FLOAT	2 FLOATS
2	Diagnostic mode	NORMAL mode (leave in this way)
3	For Wired probe	For RF probe
4	Select protocol n. 1	Select protocol n. 2

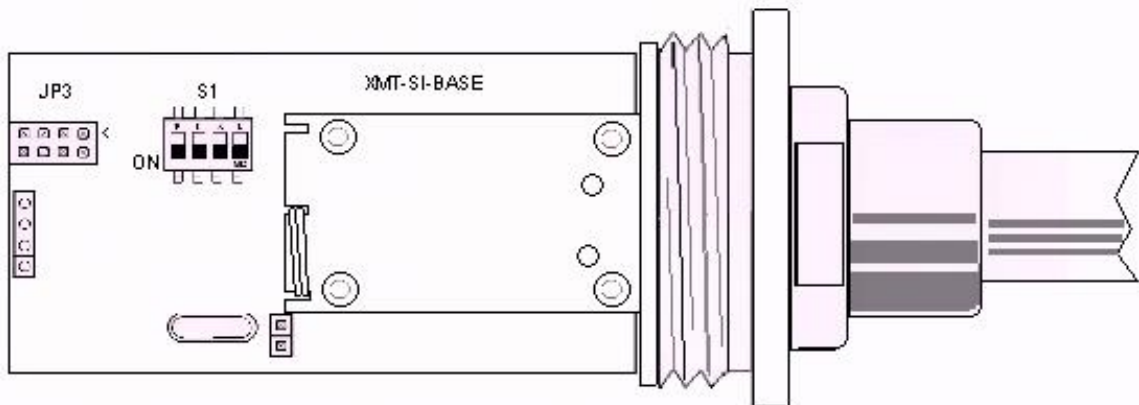

MODEL XMT-SI-RF

DIP-SWITCH PROGRAMMATION

There are several operation modes that can be selected through the internal DIP-Switch. These operation modes can be applied to RF probes. The operation mode defined will amend the life battery duration. Below is a table which gives the information on the estimated life battery referred to the selected operation mode.

Radiofrequency probes use a frequency of 169,4Mhz, transmit on channel 5 (169,468 MHz) power 200mW.

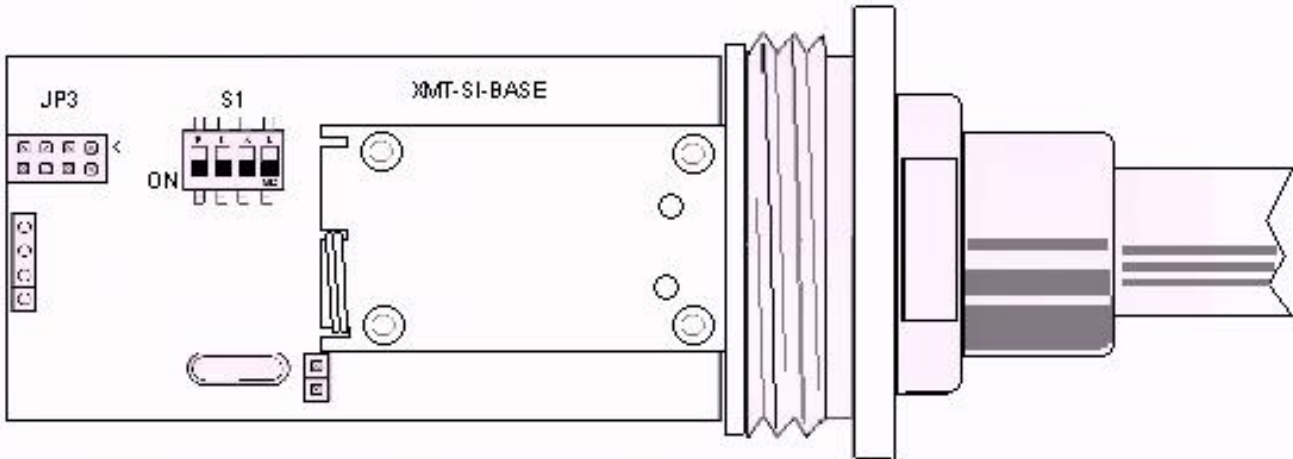

DIPSW1	DIPSW2	DIPSW3	DIPSW4	MODE
OFF	OFF	OFF	OFF	OP1
ON	OFF	OFF	OFF	OP2
OFF	ON	OFF	OFF	OP3
ON	ON	OFF	OFF	OP4
OFF	OFF	ON	OFF	OP5
ON	OFF	ON	OFF	OP6
OFF	ON	ON	OFF	OP7
ON	ON	ON	OFF	OP8
----	----	----	----	----
ON	ON	OFF	ON	OP12
OFF	OFF	ON	ON	OP13
ON	OFF	ON	ON	OP14
OFF	ON	ON	ON	OP15
ON	ON	ON	ON	OP16

DIP-Switch are read during startup of the device. Every change made when the device is switched on won't be considered. It is necessary to switch off and restart again the device so that the changes are applied.

- **OP1: wake up probe every 1 minute (Default setting)**
 - OP2: wake up probe every 2 minute
 - OP3: wake up probe every 4 minute
 - OP4: wake up probe every 5 minute
 - OP5: wake up probe every 10 minute
 - OP6: not active, don't set
-
- OP11: not active, don't set
 - OP12: wake up probe every 30 seconds
 - OP13: wake up probe every 20 seconds
 - OP14: wake up probe every 15 seconds
 - OP15: wake up probe every 10 seconds
 - OP16: wake up probe every 5 seconds

Normally the probe is in sleeping mode in order to optimize the life battery duration.

At the set time the probe wakes up and makes the measure. If the measure of the product or of the water has a difference of +/-1 mm compared to that previously measured, the probe transmits the measure via radio or via cable, otherwise it returns in sleeping mode.

In any case after 10 minutes of non-transmission, the probe transmits the data even if they are unchanged to avoid the time-out of the system. This has to be considered as an heart-beat for the receiver. The receiver should activate a non-rx alarm after 1 hour of transmission absence.

At power up:

During the probe installation open the housing of the probe to connect the battery to the electronic board, because the probe is supplied with battery disconnected to preserve the charge until the use of the probe.

If the operation mode defined is between 1 and 5 after power up, the probe transmits data every 5 seconds for 24 hours, after that the probes goes into the set operation mode.

This allow to check the signal during the installation without waiting the programmed sleeping time.

This function won't be available if the chosen operation mode is between 12 and 16.

TIME LIFE BATTERY ESTIMATION FOR RF PROBES DEPENDING ON THE OPERATION MODE DEFINED

It is possible to set different levels of transmission power.

Default value is 200mW.

OP MODE	Transmission every x minutes	Years of duration of the battery if the transmission power is 200mW
1	1	2,6
2	2	4,1
3	4	5,7
4	5	6,2
5	10	7,6
----	----	----
12	30 sec	1,3
13	20 sec	0,9
14	15 sec	0,7
15	10 sec	0,5
16	5 sec	0,3

These data are calculated considering the worst conditions, assuming that for example the probe is programmed to transmit every minute and effectively it transmits every minute. Indeed the probe will not transmit if there is not a difference of at least 1 mm, so the life battery will be higher than that shown into the above table.

These data are calculated based on a 16.5 Ah battery. Use only battery supplied by Start Italiana since this is an Intrinsically Safe certificated device and the supplied batteries satisfy the requirements. If another type of battery is used the Intrinsically Safe certification is compromised and Start Italiana won't be responsible in case any failure occurs.

MODEL XMT-SI-485

DIP-SWITCH PROGRAMMATION

For this model it is possible to set an address between 1 and 15 in case it would not be possible to use the address defined into the memory, which coincides with the serial number.

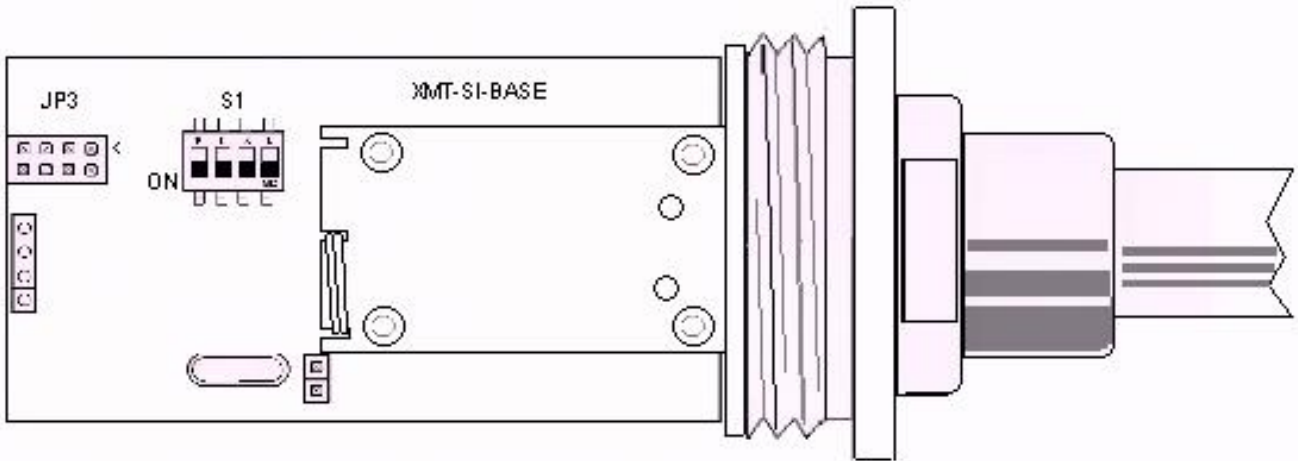

DIPSW1	DIPSW2	DIPSW3	DIPSW4	ADDRESS
OFF	OFF	OFF	OFF	MEMORY ADDRESS
ON	OFF	OFF	OFF	1
OFF	ON	OFF	OFF	2
ON	ON	OFF	OFF	3
OFF	OFF	ON	OFF	4
ON	OFF	ON	OFF	5
OFF	ON	ON	OFF	6
ON	ON	ON	OFF	7
----	----	----	----	----
ON	ON	OFF	ON	11
OFF	OFF	ON	ON	12
ON	OFF	ON	ON	13
OFF	ON	ON	ON	14
ON	ON	ON	ON	15

DIP-Switch are read only at startup of the device.

Every change made when the device is switched on won't be considered. It is necessary to switch off and restart again the device so that the changes are applied.

TRANSMISSION PROTOCOL

Protocol valid for XMT-SI-485, XMT-SI-485-LOG and TTL probes in polling mode.
Do not use this protocol for RF probes.

Transmission parameters

- Speed: 9600 bps
- Parity: none
- Data bit: 8
- Stop bit: 1
- Flow control: none

Using this setting the probe is not placed in sleeping mode but it is always active receiving all the data transmitted on the bus and answering only when a message is coming on its address.

Two different replies are available in order to grant compatibility with previous protocols.

Jumper nr	INSERTED	REMOVED
1	1 FLOAT	2 FLOATS
2	Diagnostic mode	Normal mode (don't change it)
3	Polling Mode	Push mode
4	Procotol selection answer 1	Protocol selection answer 2

Command for data reading:

M[address]CrLf

Reply nr.1:

00348=0=+216=03722=0038=241

address=status=temperature in 10th of degree=product in 10th of mm=water in mm= checksum

Reply nr.2:

00348N0=+217=00682.84=00073.22=098

address=status=temperature in 10th of degree=product in mm=water in mm= checksum

Checksum calculation:

ASCII sum from the beginning up to the last one = included module 255.

Status:

0 = OK

1 probe unable to do the measure, check number of floats inserted with reference to the jumper setting, the orientation, check if the shaft is bended and if there is presence of humidity inside the probe.

XMT-SI-485-LOG PROBE WITH MEMORY AND DATA LOGGER FUNCTIONALITY

WHAT HAPPENS IF POWER SUPPLY GOES OFF?
PROBE CONTINUES TO WORK AND STORE MOVEMENT DATA

WHAT HAPPENS IF POLLING IS DEACTIVATED OR DATA POLLING IS LOST?
PROBE CONTINUES TO WORK AND STORE MOVEMENT DATA

This model belongs to the XMT-SI-485 family with data logger functionality which is normally activated when external power supply goes off and data polling is lost.

Probe works normally when external power supply is present, in polling mode, and connected to RS485 line. When external power supply is missing, the internal battery is automatically connected to the electronic through an additional board of battery management.

The following actions are performed:

- Start a minute counter set at 0.
- Store the mm value measured at this time.
- Goes in power down mode.
- Every minute it wakes up, measures the level and checks if there is a difference of +/-1 mm compared to the previous measure. If major it stores the data.
- Returns in power down mode until the next minute.
- This continues until the external supply is missing.
- When external supply returns there is up to 1 minute of latency before the probe is able to reply, because it must go out of power down mode.

The same procedure happens when polling is missing for more than 1 consecutive minute.

The maximum capacity of event recorded is 3968. Supposing that there is one record every 10 minutes as average the logger time is around 27 days. After that the newer will delete the older.

With this functionality, even if the power supply is disconnected by the probe or if data transmission is interrupted, it is possible to track all the internal tank movement for a future downloading.

When the external power supply returns or data polling is re-activated, the probe returns to normal working suspending the logger data recording.

DATA LOGGER PROTOCOL

In this case two additional commands have been added in order to manage the logger data reading and deleting:

Data logger reading:
S[address]CrLf

Data logger deleting:
Z[address]CrLf

Here is an example of the reply to S command:

```
S02102=00015=00237=00098=052  
S02102=00014=00228=00098=051  
S02102=00013=00225=00107=038  
S02102=00012=00208=00115=037  
S02102=00011=00204=00134=033  
S02102=00010=00183=00155=041  
S02102=00009=00173=00169=053
```

S02102=00008=00166=00159=053
 S02102=00007=00155=00146=046
 S02102=00006=00142=00136=040
 S02102=00005=00135=00129=043
 S02102=00004=00134=00115=036
 S02102=00003=00002=00113=027
 S02102=00002=00001=00102=023
 S02102=00001=00000=00102=021

Meaning of the fields:

S[address]=[record_counter]=[minutes_from_starting_logging]=[mm]=[chk]CrLf

Address: is the probe address

record_counter: is the progressive number of stored record

minutes_from_starting_logging: is related to the minute to which the stored record refers to. Minutes are calculated starting from the moment of power loss or after 1 minute of polling missing.

mm: level stored at that moment

Chk: ASCII sum of the entire frame included the last = mod 255.

At minute nr. 0 there is always the value in mm at the power off moment. At the last record transmitted there is always the value of the measurement referred to the moment of the power on after return of external supply. Looking at the above example from minute 2 to minute 134 the level has not changed.

Expanding the above data it is possible to have the real movement of the level inside the tank registered during the power loss or polling.

This graph has been generated expanding the above 15 records stored in 237 minutes of power loss.

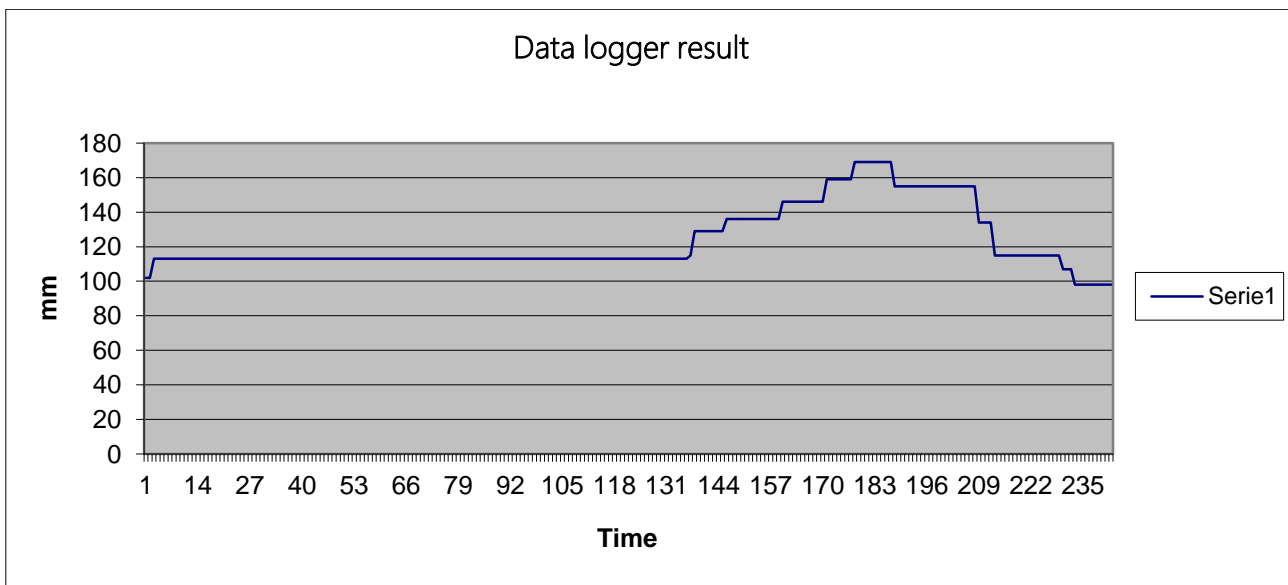

NOTE: it is possible to send S command several times, will be always displayed the same results which are the logger content. The probe will transmit records con consecutively but on groups of 16 records, it is necessary to wait 1 second in order to let the receiver system to flush and elaborate the buffer. Then further 16 records will be send and so on. If during this delay time the probe is receiving an ESC command [0x1b] the transmission history will be stopped and probe goes to normal operation.

Once all the data have been read, it is suggested to perform Z command in order to delete the logger content. This is suggested because in case of another power loss the probe can store records starting from minute 0.

It happens the same on a probe that is not queried for a consecutive minute, also in this case a new record session starts with storage from minute 0.

If the buffer is empty performing command S the probe will not send any answer.

This option is available both for new probes and for a retrofit on existing intrinsically safe probes. In this case probes should be returned in factory for adding battery, longer housing and firmware modification.

PS: OPERATION TO BE PERFORMED AFTER INSTALLATION

During the probe installation open the housing of the probe to connect the battery to the electronic board, because the probe is supplied with battery disconnected to preserve the charge until the use of the probe. In this case the probe starts immediately to register data because external power is off. Then the probe is moved in order to be inserted inside the tank and start to store data, but they don't have any meaning since they belong to installation movements.

We strongly recommend to issue Z command in order to cancel those data and start with empty buffer.

BLACK SEAL VERSION

DESCRIPTION

This Magnetostrictive probe belongs to the same family of XMT-SI-485 with data logger functionality which is automatically activated when the external power supply and/or data go off.

When external power supply is present, as the normal case, probe works as usual replying to the polling protocol. When the power/data go off, an internal battery is automatically connected to the electronic and starts to store movement data into its internal memory keeping lately available for download.

This option is available both for the new probes and for the old probe as a retrofit.

DIFFERENT VERSION FOR DIFERENT APPLICATIONS

- radio wireless, battery powered
- wired RS485 LOG: tank level data saving in case of power failure, 1 month of memory.

OPERATING GUIDE

When external power supply is operational, as the normal case, the probe operates as usual in polling mode.

With no power/data, an internal battery is automatically connected to the electronics which begins memorizing data movements in its internal memory for subsequent downloading on restoring of normal operation condition.

ATEX, CE, PROTECTION, COMPLIANCE

Intrinsically safe certificate CEC 09 ATEX131 REV. 3 II 1G Ex ia IIB T4 Ga II 1D Ex t IIIC T 135 °C Da IP66/68.

MAIN FEATURE

- Bend-proof, strong Ø 48 mm. aluminium shaft with special antistatic hard oxidation treatment: stronger than stainless steel pipes.
- Integrated floats: preventing theft attempts, suitable for turbulent flowing liquids.
- Memory: data saving in case of power failure; should cable be cut or removed, data are saved in probe internal memory.
- Supports tele-diagnostic /maintenance functions, remote configuration of operation parameters.
- Connection to the tank: inside riser.
- Circular connection.
- Power supply: 12 VDC / battery.
- RS485 serial port / antenna.
- IP68 protection (submersible up to 1,2 m. per 24 hours).
- Calculation of data relating to:
 - Product level in 0,01 mm
 - Interface level in 0,01 of mm. (water presence detection)
 - Product mean temperature up to max. 5 integrated digital sensors.
- Standard measuring accuracy: +/- 0,5 mm.
- Standard resolution: +/- 0,01 mm.
- Temperature accuracy range -20 +70 °C: +/- 0,2 °C.
- Temperature resolution: ± 0,0625 °C.



ATEX CERTIFICATION AND NOTIFICATION



Organismo Notificato n. 1131

- [1] **CERTIFICATO DI ESAME CE DEL TIPO (AII. III)**
EC-TYPE EXAMINATION CERTIFICATE (Annex III) 
- [2] **Apparecchio o Sistema di Protezione inteso per l'uso in atmosfere potenzialmente esplosive, Direttiva 94/9/CE**
Equipment or Protective Systems Intended for use in Potentially Explosive Atmospheres, Directive 94/9/EC
- [3] **Certificato di Esame CE del Tipo numero**: CEC 09 ATEX 131 Rev.4
EC-Type Examination Certificate number 14/2010 -AET604
- [4] **Apparecchio o Sistema di Protezione**:
Equipment or Protective System
- Codice sensore di livello magnetostrittivo con uscita seriale RS485 alimentato esternamente tipo XMT-SI-485**
Codice sensore di livello magnetostrittivo con uscita RS485 alimentato esternamente e con batteria interna per memorizzazione eventi in assenza di alimentazione esterna e mancato polling dati tipo XMT-SI-485-LOG
Codice sensore di livello magnetostrittivo con uscita analogica 4-20 mA/Hart Protocol tipo XMT-SI-4-20mA
Codice sensore di livello magnetostrittivo alimentato a batteria, wireless tipo XMT-SI-RF
Codice sensore di livello di livello magnetostrittivo con uscita TTL collegato a dispositivo radio esterno certificato a sicurezza intrinseca ed alimentato a batteria, tipo XMT-SI-TTL
Code magnetostrictive sensor with serial output RS485 type XMT-SI-485
Code magnetostrictive sensor with serial output RS485 with inside battery to record events without external supply and without data polling type XMT-SI-485-LOG
Code magnetostrictive sensor with analogical output 4-20mA/Hart Protocol type XMT-SI-4-20mA.
Code magnetostrictive sensor with battery power, wireless type XMT-SI-RF
Code magnetostrictive sensor with TTL output connected to intrinsically safe external radio appliance and battery-powered type XMT-SI-TTL
- Codice sensore di livello a catena reed con uscita RS485 alimentato esternamente tipo XCR-SI-485**
Codice sensore di livello a catena reed con uscita RS485 alimentato esternamente e con batteria interna per memorizzazione eventi in assenza di alimentazione esterna e mancato polling dati tipo XCR-SI-485-LOG
Codice sensore di livello a catena reed con uscita analogica 4-20 mA/ Hart protocol tipo XCR-SI-4_20mA
Codice sensore di livello a catena reed alimentato a batteria con uscita RF tipo XCR-SI-RF
Codice sensore di livello a catena reed con uscita TTL collegato a dispositivo radio esterno certificato a sicurezza intrinseca ed alimentato a batteria tipo XCR-SI-TTL
Code reed chain sensor with serial output RS485 type XCR-SI-485
Code reed chain sensor with serial output RS485 with inside battery to record events without external supply and without data polling type XCR-SI-485-LOG
Code reed chain sensor with analogical output 4-20mA/Hart Protocol type XCR-SI-4-20mA.
Code reed chain sensor with battery power, wireless type XCR-SI-RF

This certificate may only be reproduced in its entirety and without any change, schedule included

CEC - CONSORZIO EUROPEO CERTIFICAZIONE S.C.A.R.L.

Sede Legale e Uffici: Via Pisacane, 46- 20025 LEGNANO (Mi) Italy - tel. +39.0331.442 266- fax +39.0331.440 054

www.consorzioccc.com - info@consorzioccc.com - C.F./P.IVA 13073160155 - Reg. Impr. MI 13073160155 - R.E.A. 1612104
AET_CEC rev.3 2014/04/15 Page 1 of 6

CEC – CONSORZIO EUROPEO CERTIFICAZIONE
Certificato di Esame CE del Tipo
 EC-Type Examination Certificate



Organismo Notificato n. 1131

Code reed chain sensor with TTL output connected to intrinsically safe external radio appliance and battery-powered type XCR-SI-TTL

Codice sensore ON-OFF switch con uscita RS485 alimentato esternamente tipo XLR-SI-485

Codice sensore ON-OFF switch con uscita RS485 alimentato esternamente e con batteria interna per memorizzazione eventi in assenza di alimentazione esterna e mancato polling dati tipo XLR-SI-485-LOG

Codice sensore ON-OFF switch con uscita 4-20mA/Hart protocol opzionale tipo XLR-SI-4_20mA

Codice sensore ON-OFF switch con uscita RF alimentato a batteria tipo XLR-SI-RF

Codice sensore ON-OFF switch con uscita TTL collegato a dispositivo radio esterno certificato a sicurezza intrinseca ed alimentato a batteria tipo XLR-SI-TTL

Code ON-OFF switch sensor with serial output RS485 type XLR-SI-485

Code ON-OFF switch sensor with serial output RS485 with inside battery to record events without external supply and without data polling type XLR-SI-485-LOG

Code ON-OFF switch sensor with analogical output 4-20mA/Hart Protocol type XLR-SI-4-20mA.

Code ON-OFF switch sensor with battery power, wireless type XLR-SI-RF

Code ON-OFF switch sensor with TTL output connected to intrinsically safe external radio appliance and battery-powered type XLR-SI-TTL

- [5] **Costruttore**: **START ITALIANA S.r.l.**
 Manufacturer
- [6] **Indirizzo**: **Via Pola, 6 – 20813 Bovisio Masciago (MB) - Italy**
 Address
- [7] **Questo apparecchio o sistema di protezione ed ogni sua variante approvata è descritto nell'allegato al presente certificato e nei documenti descrittivi in esso richiamati.**
 This equipment or protective system and any acceptable variation thereto is specified in the schedule to this certificate and the documents therein referred to.
- [8] **Il CEC, organismo notificato n° 1131, in conformità all'articolo 9 della Direttiva 94/9/CE del Consiglio dell'Unione Europea del 23 Marzo 1994, certifica che questa apparecchiatura o sistema di protezione è conforme ai Requisiti Essenziali di Sicurezza e Salute per il progetto e la fabbricazione di apparecchiature e sistemi di protezione destinati ad essere utilizzati in atmosfere potenzialmente esplosive, definiti nell'Allegato II della Direttiva.**
 CEC, notified body No. 1131, in accordance with Article 9 of the Council Directive 94/9/EC of 23 March 1994, certifies that this equipment or protective system has been found to comply with the Essential Health and Safety Requirements relating to the design and construction of equipment and protective systems intended for use in potentially explosive atmospheres given in Annex II to the Directive.
- I risultati dell'esame e dei test sono descritti nel rapporto confidenziale elencato nella sezione 16.**
 The examination and test results are recorded in confidential reports listed in section 16.
- [9] **La conformità ai Requisiti Essenziali di Sicurezza e Salute è assicurata dalla conformità alle:**
 Compliance with the Essential Health and Safety Requirements has been assured by compliance with:
EN 1127-1: 2011; EN 60079-0: 2012; EN 60079-11: 2012; EN60079-25: 2010;
EN 60079-26: 2007; EN 60079-31: 2009
- Nel caso in cui tra le norme tecniche citate fossero presenti norme non armonizzate, la conformità ai Requisiti essenziali in materia di Sicurezza e Salute è comunque stata verificata.**
 If standards not listed in the list of ATEX Harmonised Standards are used, compliance to the Essential Health and Safety Requirements is verified anyway.

Il simbolo "X" posto dopo il numero del certificato indica che l'apparecchiatura o il sistema di

CEC - CONSORZIO EUROPEO CERTIFICAZIONE S.C.A.R.L.

Sede Legale e Uffici: Via Pisacane, 46- 20025 LEGNANO (Mi) Italy - tel. +39.0331.442 266- fax +39.0331.440 054
 www.consorzioccc.com - info@consorzioccc.com - C.F./P.IVA 13073160155 – Reg. Impr. MI 13073160155 – R.E.A. 1612104

CEC – CONSORZIO EUROPEO CERTIFICAZIONE
Certificato di Esame CE del Tipo
EC-Type Examination Certificate

Organismo Notificato n. 1131

- [10] **protezione è soggetto a condizioni speciali per un utilizzo sicuro, specificate nell'allegato al presente certificato.**

If the sign "X" is placed after the certificate number, it indicates that the equipment or protective system is subject to special conditions for safe use specified in the schedule to this certificate.

- [11] **Questo Certificato di esame CE del Tipo è relativo soltanto al progetto, agli esami ed alle prove dell'apparecchio o sistema di protezione specificato in accordo con la Direttiva 94/9/CE. Ulteriori requisiti di questa Direttiva si applicano al processo di produzione e fornitura dell'apparecchiatura o sistema di protezione. Questi requisiti non sono oggetto del presente certificato.**

This EC-Type Examination Certificate relates only to the design, examination and tests of the specified equipment or protective system in accordance to the Directive 94/9/EC. Further requirements of the Directive apply to the manufacturing process and supply of this equipment or protective system. These are not covered by this certificate.

- [12] **L'apparecchiatura o sistema di protezione deve riportare i seguenti contrassegni:**

The marking of the equipment or protective system shall include the following:



II 1G Ex ia IIB T4 Ga



II 1D Ex ta IIIC T135°C Da IP66/68

FISCO Field device Exia IIC T4

Legnano, 18 02 2015



PRD n° 114B ISP n° 071E

Membro degli Accordi di Mutuo Riconoscimento EA, IAF e ILAC
Signatory of EA, IAF and ILAC Mutual Recognition Agreement

CONSORZIO EUROPEO CERTIFICAZIONE
L'ORGANO DELIBERANTE

Il Direttore Tecnico
(A. FUGAZZI)

Il Direttore Generale
(L. TIMOSSI)

CEC - CONSORZIO EUROPEO CERTIFICAZIONE S.C.A.R.L.

Sede Legale e Uffici: Via Pisacane, 46- 20025 LEGNANO (Mi) Italy - tel. +39.0331.442 266- fax +39.0331.440 054
www.consorzioccec.com - info@consorzioccec.com - C.F./P.IVA 13073160155 - Reg. Impr. MI 13073160155 - R.E.A. 1612104

Page 3 of 6

CEC – CONSORZIO EUROPEO CERTIFICAZIONE
Certificato di Esame CE del Tipo
EC-Type Examination Certificate

Organismo Notificato n. 1131

- [13] **ALLEGATO – SCHEDULE**
- [14] **CERTIFICATO DI ESAME CE DEL TIPO n° CEC 09 ATEX 131 Rev.4**
to EC-TYPE EXAMINATION CERTIFICATE no. CEC 09 ATEX 131 Rev.4

[15] **Descrizione – Description**

Sensore Magnetostrittivo a sicurezza intrinseca:

Codice sensore di livello magnetostrittivo con uscita seriale RS485 tipo XMT-SI-485

Codice sensore di livello magnetostrittivo con uscita RS485 alimentato esternamente e con batteria interna per memorizzazione eventi in assenza di alimentazione esterna e mancato polling dati tipo XMT-SI-485-LOG

Codice sensore di livello magnetostrittivo con uscita analogica 4-20mA/Hart Protocol tipo XMT-SI-4-20mA

Codice sensore di livello magnetostrittivo alimentato a batteria, wireless tipo XMT-SI-RF

Codice sensore di livello magnetostrittivo con uscita TTL collegato a dispositivo radio esterno certificato a sicurezza intrinseca ed alimentato a batteria, tipo XMT-SI-TTL

Sensore a catena reed a sicurezza intrinseca:

Codice sensore di livello a catena reed con uscita RS485 alimentato esternamente tipo XCR-SI-485

Codice sensore di livello a catena reed con uscita RS485 alimentato esternamente e con batteria interna per memorizzazione eventi in assenza di alimentazione esterna e mancato polling dati tipo XCR-SI-485-LOG

Codice sensore di livello a catena reed con uscita analogica 4-20 mA/ Hart protocol tipo XCR-SI-4_20mA

Codice sensore di livello a catena reed alimentato a batteria con uscita RF tipo XCR-SI-RF

Codice sensore di livello a catena reed con uscita TTL collegato a dispositivo radio esterno certificato a sicurezza intrinseca ed alimentato a batteria tipo XCR-SI-TTL

Sensore ON-OFF switch a sicurezza intrinseca:

Codice sensore ON-OFF switch con uscita RS485 alimentato esternamente tipo XLR-SI-485

Codice sensore ON-OFF switch con uscita RS485 alimentato esternamente e con batteria interna per memorizzazione eventi in assenza di alimentazione esterna e mancato polling dati tipo XLR-SI-485-LOG

Codice sensore ON-OFF switch con uscita 4-20mA/Hart protocol opzionale tipo XLR-SI-4-20mA

Codice sensore ON-OFF switch con uscita RF alimentato a batteria tipo XLR-SI-RF

Codice sensore ON-OFF switch con uscita TTL collegato a dispositivo radio esterno certificato a sicurezza intrinseca ed alimentato a batteria tipo XLR-SI-TTL

Caratteristiche nominali / Dati Elettrici – Rated characteristics / Electrical data

Nel collegamento elettrico tra barriere a sicurezza intrinseca e sensori, vengono installati dei diodi. Questi hanno lo scopo di ridurre le capacità interne ad un valore trascurabile.

La parte elettronica è costituita da una scheda di preamplificazione, una scheda madre di elaborazione analogica e digitale del segnale e di schede plug-in che ne caratterizzano la funzionalità.

Ci saranno 5 tipologie di schede plug-in:

- alimentazione esterna + RS485
- alimentazione esterna + RS485 + batteria interna per DATA LOGGER in assenza di alimentazione esterna o polling dati
- modulo RF + alimentazione a batteria
- modulo 4-20mA 2 fili (Hart protocol opzionale)+ gestione della alimentazione
- prodotto OEM con uscita TTL da collegare ad un apparato radio senza collegamenti esterni già certificato.

Intrinsically Safe Magnetostrictive Sensor.

Code magnetostrictive sensor with serial output RS485 type XMT-SI.

Code magnetostrictive sensor with serial output RS485 with inside battery to record events without external supply and without data polling type XMT-SI-485-LOG

Code magnetostrictive sensor with analogical output 4-20mA/Hart Protocol type XMT-SI-4-20mA

Code magnetostrictive sensor with battery power, wireless type XMT-SI-RF

Code magnetostrictive sensor with TTL output connected to intrinsically safe external radio appliance and battery-powered type XMT-SI-TTL

Intrinsically safe reed chain Sensor.

Code reed chain sensor with serial output RS485 type XCR-SI-485

Code reed chain sensor with serial output RS485 with inside battery to record events without external supply and without data polling type XCR-SI-485-LOG

CEC - CONSORZIO EUROPEO CERTIFICAZIONE S.C.A.R.L.

Sede Legale e Uffici: Via Pisacane, 46- 20025 LEGNANO (Mi) Italy - tel. +39.0331.442 266- fax +39.0331.440 054
www.consorzioccc.com - info@consorzioccc.com - C.F./P.IVA 13073160155 – Reg. Impr. MI 13073160155 – R.E.A. 1612104

Page 4 of 6

CEC – CONSORZIO EUROPEO CERTIFICAZIONE
Certificato di Esame CE del Tipo
EC-Type Examination Certificate



Organismo Notificato n. 1131

[13]

ALLEGATO – SCHEDULE

[14]

CERTIFICATO DI ESAME CE DEL TIPO n° CEC 09 ATEX 131 Rev.4
to EC-TYPE EXAMINATION CERTIFICATE no. CEC 09 ATEX 131 Rev.4

Code reed chain sensor with analogical output 4-20mA/Hart Protocol type XCR-SI-4-20mA.
Code reed chain sensor with battery power, wireless type XCR-SI-RF
Code reed chain sensor with TTL output connected to intrinsically safe external radio appliance and battery-powered type XCR-SI-TTL
Intrinsically safe On-OFF switch sensor
Code ON-OFF switch sensor with serial output RS485 type XLR-SI-485
Code ON-OFF switch sensor with serial output RS485 with inside battery to record events without external supply and without data polling type XLR-SI-485-LOG
Code ON-OFF switch sensor with analogical output 4-20mA/Hart Protocol type XLR-SI-4-20mA.
Code ON-OFF switch sensor with battery power, wireless type XLR-SI-RF
Code ON-OFF switch sensor with TTL output connected to intrinsically safe external radio appliance and battery-powered type XLR-SI-TTL
A connection between intrinsic safety barriers and sensors are installed diodes. These are intended to reduce domestic capacity to a negligible value.

The electronic part consists of a preamp card, a motherboard of analogical and digital signal processing and plug-in cards that characterize the feature. Five type electrical output available:

- External Power + RS485
- External power supply + RS485 + internal battery per DATA LOGGER in case of external power off or data pulling off
- RF module + battery power
- Module 4-20 mA 2-wire (Optional Hart protocol) + power management
- OEM product with TTL out connect with radio apparatus

	Ui (V)	Ii (mA)	Li	Ci	Uo(V)	Io(mA)	Lo	Co
XMT-SI-485	16	125	trascurabile negligibile	trascurabile negligibile	5,2	100	trascurabile negligibile	trascurabile negligibile
XCR-SI-485								
XLR-SI-485								
XMT-SI-485-LOG	16	125	trascurabile negligibile	trascurabile negligibile	5,2	100	trascurabile negligibile	trascurabile negligibile
XCR-SI-485-LOG								
XLR-SI-485-LOG								
XMT-SI-RF	n/a	n/a	n/a	n/a	n/a	n/a	n/a	n/a
XCR-SI-RF								
XLR-SI-RF								
XMT-SI-TTL	5	125	trascurabile negligibile	trascurabile negligibile	4,6	100	trascurabile negligibile	trascurabile negligibile
XCR-SI-TTL								
XLR-SI-TTL								
XMT-SI-4_20mA	28	100	trascurabile negligibile	trascurabile negligibile				
XCR-SI-4_20mA								
XLR-SI-4_20mA								

Gli apparecchi XMT-SI-485, XCR-SI-485, XLR-SI-485; XMT-SI-485-LOG, XCR-SI-485-LOG, XLR-SI-485-LOG e XMT-SI-4_20mA, XCR-SI-4_20mA, XLR-SI-4_20mA possono essere collegati solo ad un apparecchio associato certificato a sicurezza intrinseca (barriera di sicurezza) e questa combinazione deve rispettare le norme di sicurezza intrinseca.

Negli apparecchi XMT-SI-485-LOG, XCR-SI-485-LOG, XLR-SI-485-LOG in presenza di alimentazione esterna la batteria è disconnessa dall'elettronica. La batteria viene automaticamente collegata all'elettronica quando l'alimentazione esterna è assente.

The equipments XMT-SI-485, XCR-SI-485, XLR-SI-485; XMT-SI-485-LOG, XCR-SI-485-LOG, XLR-SI-485-LOG and XMT-SI-4_20mA, XCR-SI-4_20mA, XLR-SI-4-20mA can be only connected to a certified associated intrinsically safe apparatus (safety barrier) and this combination must be compatible as regard intrinsic safety rules.

In equipments XMT-SI-485-LOG, XCR-SI-485-LOG, XLR-SI-485-LOG, when there is an external supply, the battery is disconnected from electronics. The battery is automatically connected to electronics when there is not external supply.

Test di Routine / Routine tests

EN 60079-11 §11.1: Routine tests for diode safety barriers

Avvertenze di targa / Warning label

None

CEC - CONSORZIO EUROPEO CERTIFICAZIONE S.C.A.R.L.

CEC – CONSORZIO EUROPEO CERTIFICAZIONE
Certificato di Esame CE del Tipo
EC-Type Examination Certificate

Organismo Notificato n. 1131

[13] **ALLEGATO – SCHEDULE**[14] **CERTIFICATO DI ESAME CE DEL TIPO n° CEC 09 ATEX 131 Rev.4**
to EC-TYPE EXAMINATION CERTIFICATE no. CEC 09 ATEX 131 Rev.4[16] **Rapporto numero / Report Number: CEC 14/2010 – RET 001**[17] **Condizioni speciali per un utilizzo sicuro – Special conditions for safe use**
Nessuna – None.

L'efficacia e l'affidabilità di questi apparecchi sono garantite seguendo le istruzioni del Manuale d'uso. Non sono ammesse modifiche non autorizzate rispetto al fascicolo tecnico agli atti.
Special conditions for safe use depends on correct following of manufacturer's manual. Further modification are not allowed.

[18] **Requisiti Essenziali di Sicurezza e Salute – Essential Health and Safety Requirements**

Nessuno – None. Riguardo ai Requisiti Essenziali di Sicurezza e Salute questo documento verifica la conformità solo agli standard Ex. La dichiarazione di Conformità del Produttore dichiara la conformità con altre Direttive pertinenti.

Concerning EHSR this schedule verifies the compliance with the Ex standards only. The manufacturer's Declaration of Conformity declares compliance with other relevant Directives.

[19] **Documenti descrittivi – Descriptive documents**

I documenti di riferimento listati di seguito costituiscono la documentazione tecnica dell'apparecchio o sistema di protezione oggetto di questo certificato. Questi documenti sono confidenziali e sono a disposizione delle sole autorità competenti.

Una copia di questi documenti è conservata presso l'archivio del CEC.

The descriptive documents quoted hereafter constitute the technical documentation of the equipment or protective system, subject of this certificate. This documents are confidential and they are available only to the authorities.
One copy of all documents is kept in CEC files.

Analisi dei rischi, AR15ExTR001, AR15TEST011**L'ISPETTORE INCARICATO**
Dott. Ing. Giuseppe TERZAGHI

Organo deliberante

Antonio FUGAZZI

Data: 18/02/2015

CEC - CONSORZIO EUROPEO CERTIFICAZIONE S.C.A.R.L.

Sede Legale e Uffici: Via Pisacane, 46- 20025 LEGNANO (Mi) Italy - tel. +39.0331.442 266- fax +39.0331.440 054
www.consorzioccec.com - info@consorzioccec.com - C.F./P.IVA 13073160155 – Reg. Impr. MI 13073160155 – R.E.A. 1612104
Page 6 of 6

CESI

NOTIFICATION



CESI S.p.A.
Via Rubattino 54
I-20134 Milano - Italy
Tel: +39 02 21251
Fax: +39 02 21255440
e-mail: info@cesi.it
www.cesi.it

Schema di certificazione

CESI-ATEX



PRD N. 018B
Membro degli Accordi di Mutuo Riconoscimento EA, IAF e ILAC
Signatory of EA, IAF and ILAC Mutual Recognition Agreements

ATEX N.021-1-1

- [1] **PRODUCTION QUALITY ASSURANCE NOTIFICATION**
- [2] **Equipment or Protective System or Component intended for use in potentially explosive atmospheres Directive 94/9/EC**
- [3] Notification number: **CESI 06 ATEX 031 Q**
- [4] Equipment or component type: Transmitters and level switches
Capacitive sensors for continuous liquid level measurement and discriminative function for different Terminal boxes
Magnetostrictive level sensors
Galvanically isolated barriers
Protection concepts: Flameproof enclosures "d"
Intrinsic safety "i"
Encapsulation "m"
Dust ignition protection "tD"
Mechanical protection by constructional safety "c"
Dust ignition protection "t"
Pressurization "p"
- [5] Applicant: START Italiana S.r.l.
via Pola, 6
20813 Bovisio Masciago - MB
- [6] Manufacturer: START Italiana S.r.l.
via Pola, 6
20813 Bovisio Masciago - MB
- [7] CESI, notified body n. 0722 in accordance with Article 9 of the Council Directive 94/9/EC of 23 March 1994, notifies to the applicant that the actual manufacturer has a production quality system which complies to Annex IV of the Directive.
- [8] This notification is based on audit report n. EX-B5006989 issued the 9/03/2015.
This notification can be withdrawn if the manufacturer no longer satisfies the requirement of Annex IV.
Results of periodical re-assessment of the quality system are a part of this notification.
- [9] This notification is valid until 17/03/2018 and can be withdrawn if the Manufacturer does not satisfy the production quality assurance re-assessment.
- [10] According to Article 10 [1] of the Directive 94/9/EC the CE marking shall be followed by the identification n. 0722 identifying the notified body involved in the production control stage.

This notification may only be reproduced in its entirety and without any change.

Date of 1st issue
17th March 2006

Date of renewal
17th March 2015

Translation issued 17th March 2015

Prepared
Sergio G. Giugno

Verified
Mirko Balaž

Approved
Roberto Piccin

Page 1/1

CESI S.p.A.
Testing & Certification Division



START ITALIANA S.r.l.
Via Pola, 6
20813 Bovisio Masciago MB
Tel: +39 0362.15.81.465
Fax: +39 0362.15.81.464