

3-wire current loop interface converters TH-2 and TH-8

(RS-485/RS-232 to
3-wire current loop and backwards)

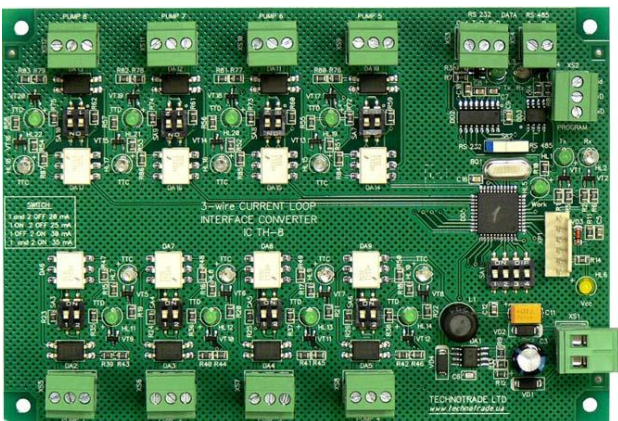
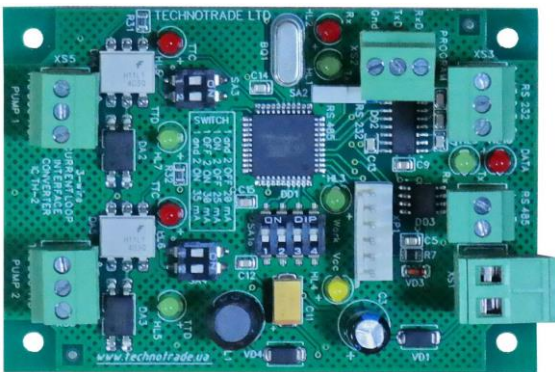

TECHNICAL GUIDE

Review date: 20 January, 2017

Revision number: 1.05

TECHNOTRADE LTD

CONTENT

REVISION HISTORY	3
PURPOSE OF THE DOCUMENT	4
APPOINTMENT	5
TECHNICAL SPECIFICATIONS	7
PCB BOARD CONNECTORS OVERVIEW	8
CONNECTION SCHEME TO PTS CONTROLLER	11
CONNECTION SCHEME TO PC COM-PORT (DATA COMMUNICATION).....	13
CONNECTION TO POWER SUPPLY	15
FIRMWARE UPDATE	16
INSTALLATION REQUIREMENTS FOR PETROL STATION	19
EXAMPLES OF FUEL DISPENSERS CONNECTION SCHEMES	21
Tokheim dispenser connection schemes	21
PCB MOUNTING BOARD	24
ORDER INFORMATION	26

REVISION HISTORY

REV	DATE	BY	SECTION	DESCRIPTION
1.05	2017.01.20	Evgeniy Vasyliiev	Firmware update procedure	Firmware update procedure using 4 th DIP-switch SA1
1.04	2014.10.22	Evgeniy Vasyliiev	Installation requirements for petrol station	Requirements to power supply, requirements to grounding, requirements to laying of cable communications
1.03	2014.01.08	Evgeniy Vasyliiev	Firmware update procedure	Description on how to update converter firmware Position of DIP-switch SA1 specified
1.02	2013.11.30	Evgeniy Vasyliiev	Connection schemes	Position of DIP-switch SA1 specified
1.01	2013.11.01	Evgeniy Vasyliiev	All	First release

PURPOSE OF THE DOCUMENT

This Technical Guide is intended for studying of 3-wire interface converters TH-2 and TH-8. It contains basic information regarding its board interfaces and connectors, configuration and adjustments, connection to fuel dispensers and external control systems (POS systems, cash registers, OPT terminals, etc), cabling, firmware update procedure. Information regarding connection to specific models of fuel dispensers and correspondent configuration of the TH interface converters can be received upon request to TECHNOTRADE LTD company.

Due to a reason that TH interface converters are constantly being developed in direction of improvements of their possibilities, changes are possible in final version, which are not described in given Technical Guide.

During the system development process given Technical Guide will be also expanded and updated and new chapters will be added. Latest version of this Technical Guide can be downloaded from the 3-wire TH interface converters web-page: <http://www.technotrade.ua/tokheim-interface-converter.html>.

TECHNOTRADE LTD hereby permits reproduction of this document as may be required by any of the customers or OEMs wishing to use it.

This document has been carefully prepared and is believed to be accurate. However TECHNOTRADE LTD, its employees and its agents do not assume responsibility for its use either directly or indirectly. TECHNOTRADE LTD shall not be liable for technical or editorial errors or omissions which may appear in this document. TECHNOTRADE LTD reserves a right to make changes to this document at any time without notice. Prospective users of this document should contact TECHNOTRADE LTD at the time they wish to use TH interface converters together with their products to become aware of any updates that may apply.

In case if you find any mistakes, omissions in this document or have any suggestions on improvements to this document, please feel free to e-mail them to our support mailbox: support_1a@technotrade.ua. We will be grateful to you for this valuable information.

All technical questions regarding the TH interface converters are welcome to be asked on support mailbox: support_1a@technotrade.ua. Our support team will be glad to help you.

Also you can call to us or visit us on:

TECHNOTRADE LTD

Ukraine, 04114 Kiev, Polupanova str. 10, office 1

Tel: +38-044-502-46-55, +38-044-502-46-77

Web: www.technotrade.ua

Mail: mail@technotrade.ua

TH-8 (8-channel converter board):

Board without terminal blocks:

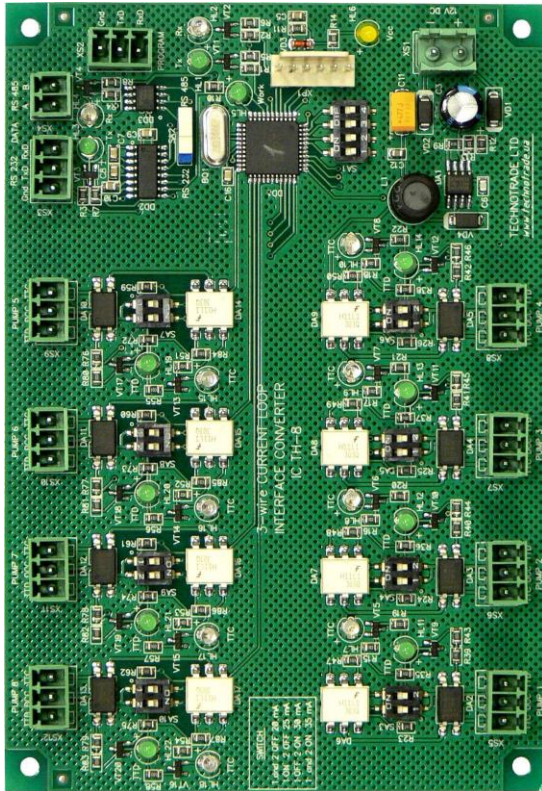

Board with terminal blocks:

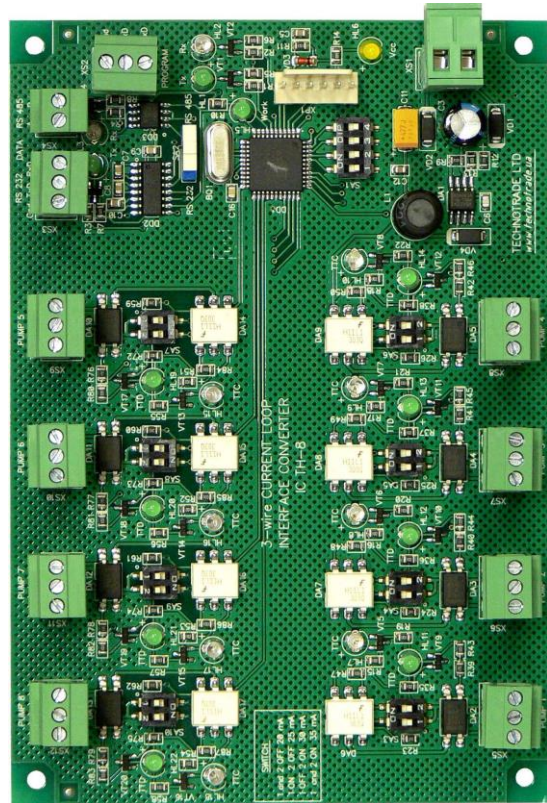

TECHNICAL SPECIFICATIONS

Specification

	TH-2	TH-8
Power supply voltage	12 V DC	
Current consumption	50 mA max	100 mA max
Temperature range	From -40°C to +80°C	
Weight	45 g	100 g
Dimensions	85 x 58 x 25 mm	145 x 100 x 20 mm

Technical characteristics

Current value in current loop interface in TTD line (transmit to dispenser)	Adjustable using DIP-switches, located on PCB board, selected values: 20 mA, 25 mA, 30 mA, 35 mA
---	--

Communication ports

	PORT NAME	INTERFACE	PURPOSE
DATA PORTS	RS-232	RS-232 (3 wires: TxD, RxD, Gnd)	Communication with a control system (POS terminal, cash register, OPT). Selection of interface is made using DIP-switch.
	RS-485	RS-485 (2-wires: line A, line B)	
PUMP PORTS	Pump ports 1-2	Optically isolated passive current loop	Connection with fuel dispensers using 3 wires (TTD, TTC, DCC). One dispenser is to be connected to each of the pump ports. Selection of current value in current loop line TTD of pump ports is made using DIP-switches.
	Pump ports 3-8 (TH-8 version only)		
PROGRAM PORT	RS-232	RS-232 (3 wires: TxD, RxD, Gnd)	Update of the interface converter firmware

PCB BOARD CONNECTORS OVERVIEW

TH-2 (2-channel converter board):

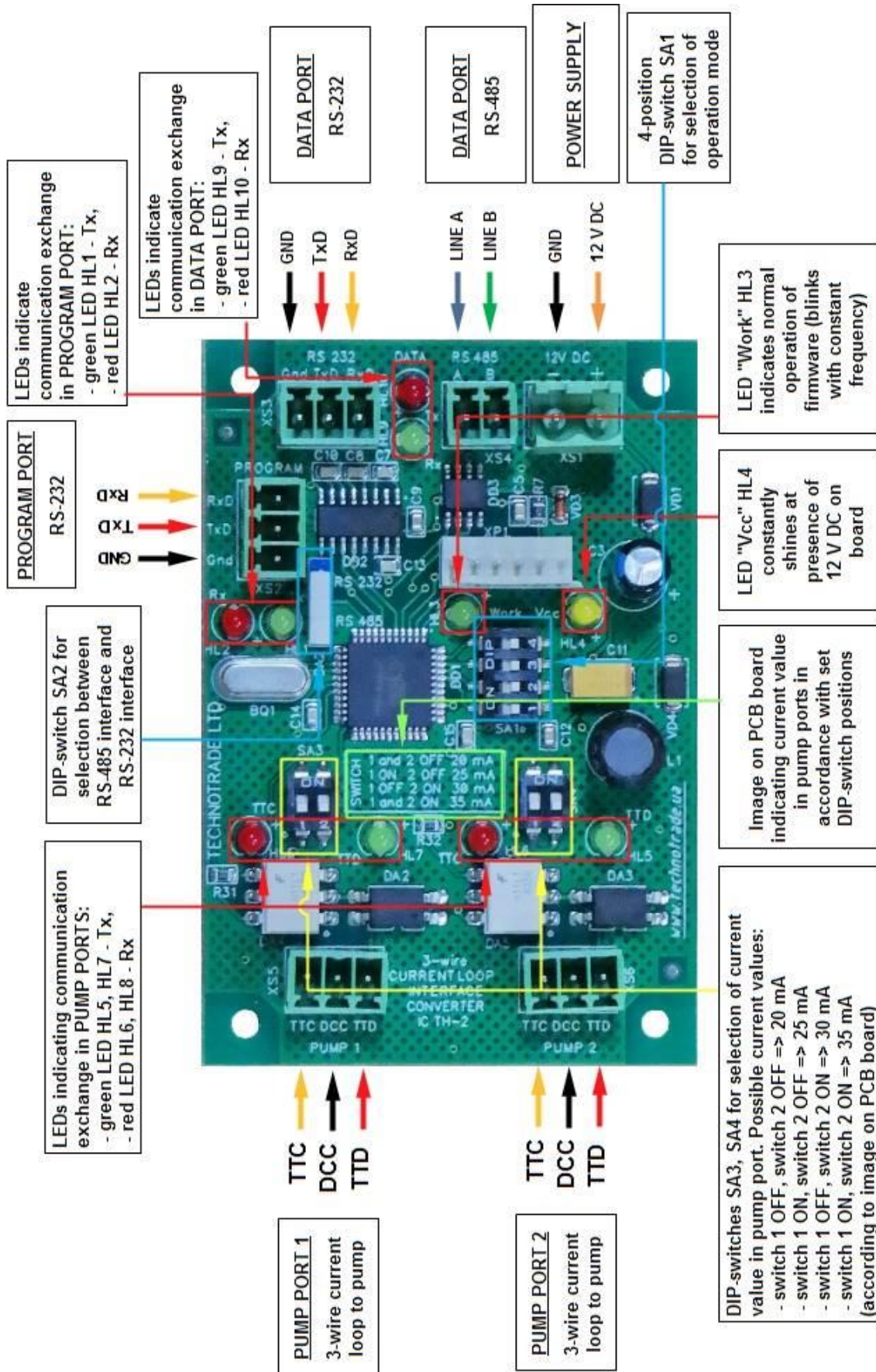

TH-8 (8-channel converter board):

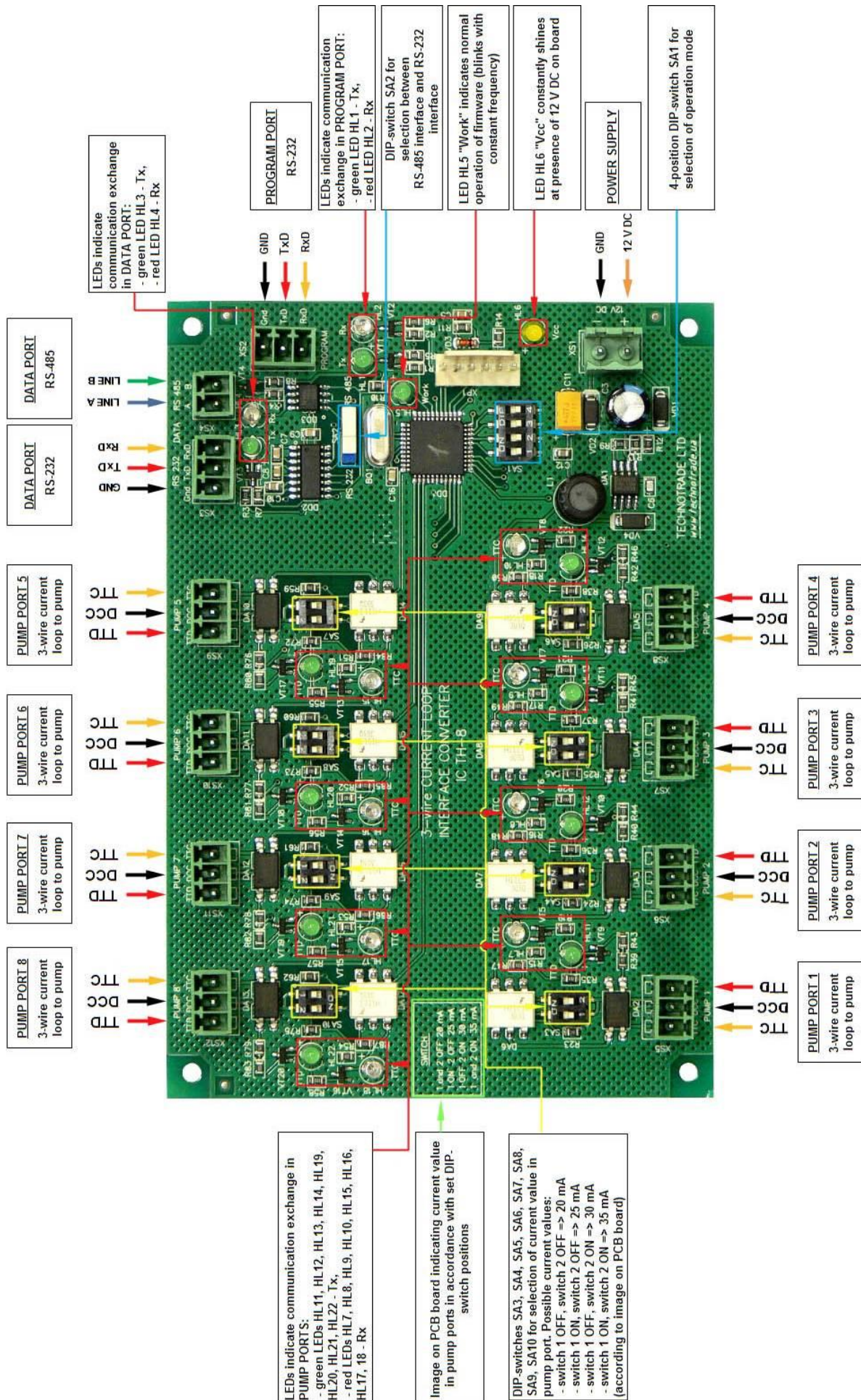

NOTE!

DIP-switch SA1 serves for selection of interface converter operation mode:

- switch 1 should be set in position "OFF"
- switch 2 should be set in position "OFF"
- switch 3 should be set in position "OFF"
- switch 4 should be set in position "OFF"

DIP-switch SA2 serves for selection of interface:

- RS-232
- RS-485 (2-wire)

DIP-switches SA3, SA4 in TH-2 and SA3, SA4, SA5, SA6, SA7, SA8, SA9, SA10 in TH-8 in each of the pump ports serve for selection of current value in TTD line of each of the pump ports and are adjusted in accordance with an image located on PCB board, which indicates current value in pump ports in accordance with set DIP-switch positions. Possible current values:

- switch 1 OFF, switch 2 OFF => 20 mA
- switch 1 ON, switch 2 OFF => 25 mA
- switch 1 OFF, switch 2 ON => 30 mA
- switch 1 ON, switch 2 ON => 35 mA

CONNECTION SCHEME TO PTS CONTROLLER

Information about PTS controller over fuel dispensers and ATG systems can be found on PTS controller web-page: <http://www.technotrade.ua/fuel-pump-controller.html>.

TH-2 (2-channel converter board):

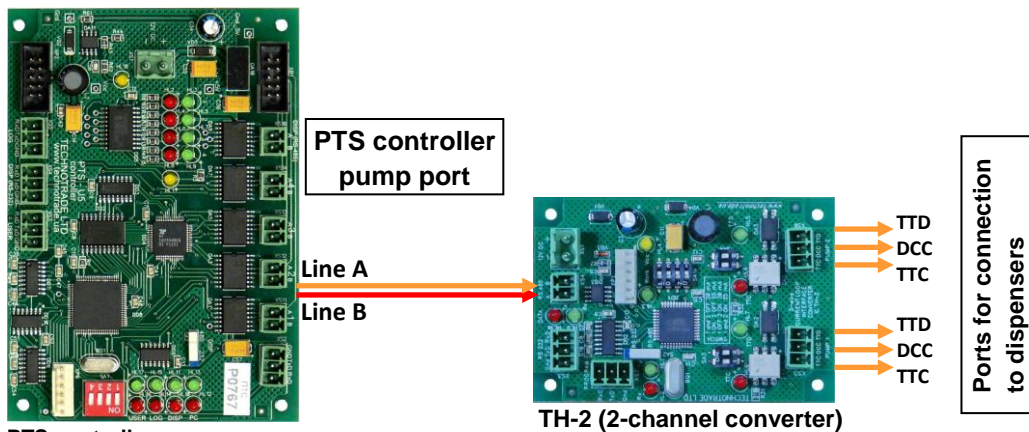

PTS controller
More info can be found on:
<http://www.technotrade.ua/fuel-pump-controller.html>

TH-8 (8-channel converter board):

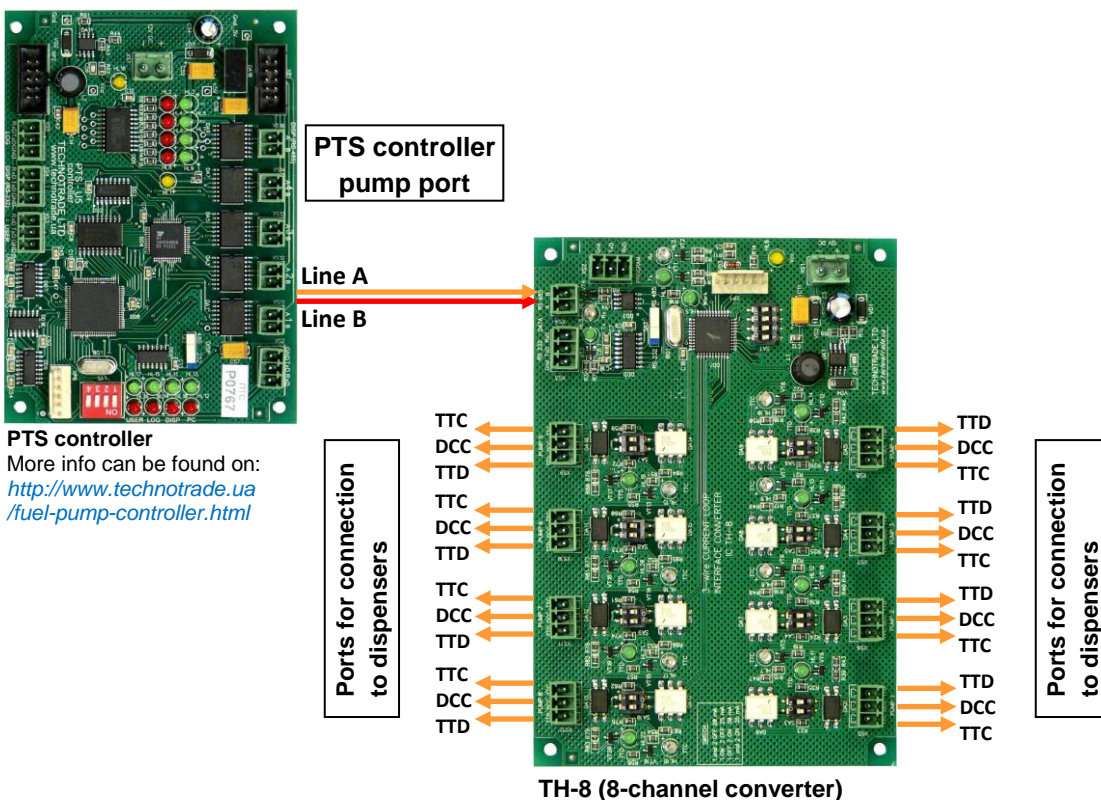

PTS controller
More info can be found on:
<http://www.technotrade.ua/fuel-pump-controller.html>

At connection using RS-485 interface please check the following:

- ✓ **DIP-switch SA1:**
 - switch 1 should be set to position "OFF"
 - switch 2 should be set to position "OFF"
 - switch 3 should be set in position "OFF"

- switch 4 should be set to position "OFF"
- ✓ **DIP-switch SA2** should be in position "RS-485"
- ✓ **LED "Work" (HL3 in TH-2 and HL5 in TH-8)**, which indicates normal operation of firmware, should be blinking with constant frequency
- ✓ **LED "Vcc" (HL4 in TH-2 and HL6 in TH-8)**, which indicates presence of 12 V DC on the board, should be constantly shining
- ✓ **Green and red LEDs "Tx" and "Rx" (HL9, HL10 in TH-2 and HL3, HL4 in TH-8)**, which indicate communication exchange in DATA PORT, should be blinking, which indicates communication with the PTS controller over RS-485 interface:
 - in case if both LEDs "Rx" and "Tx" are not blinking – there are no requests from the control system and no responses from the dispenser.
 - in case if LED "Rx" is blinking and LED "Tx" is not blinking – there are requests from the control system (LED "Rx" is blinking), but there are no responses from the dispenser.
 - in case if LED "Rx" is blinking and LED "Tx" is blinking – there are requests from the control system (LED "Rx" is blinking) and there are responses from the dispenser (LED "Tx" is blinking).
- ✓ **LEDs on pump ports**, where the dispenser is connected, should be blinking, which indicates communication with the dispenser
- ✓ **DIP-switches on pump ports**, where dispensers are connected, should be set in accordance with a current value in TTD line of current loop. Possible current values:
 - switch 1 OFF, switch 2 OFF => 20 mA
 - switch 1 ON, switch 2 OFF => 25 mA
 - switch 1 OFF, switch 2 ON => 30 mA
 - switch 1 ON, switch 2 ON => 35 mA

CONNECTION SCHEME TO PC COM-PORT (DATA COMMUNICATION)

Control over dispensers through the interface converter from a personal computer:

TH-2 (2-channel converter board):

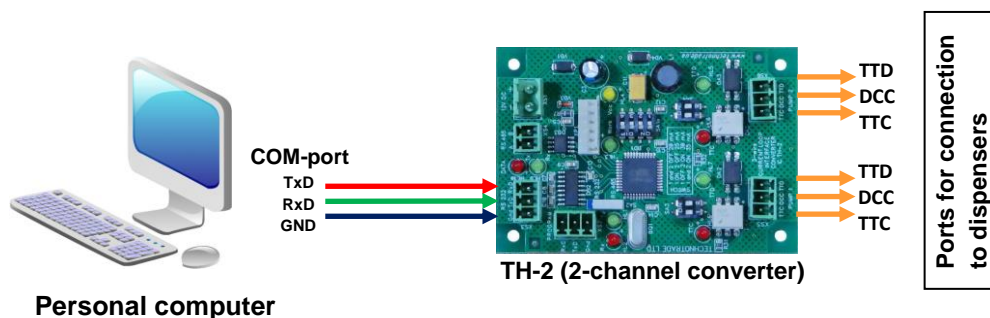

TH-8 (8-channel converter board):

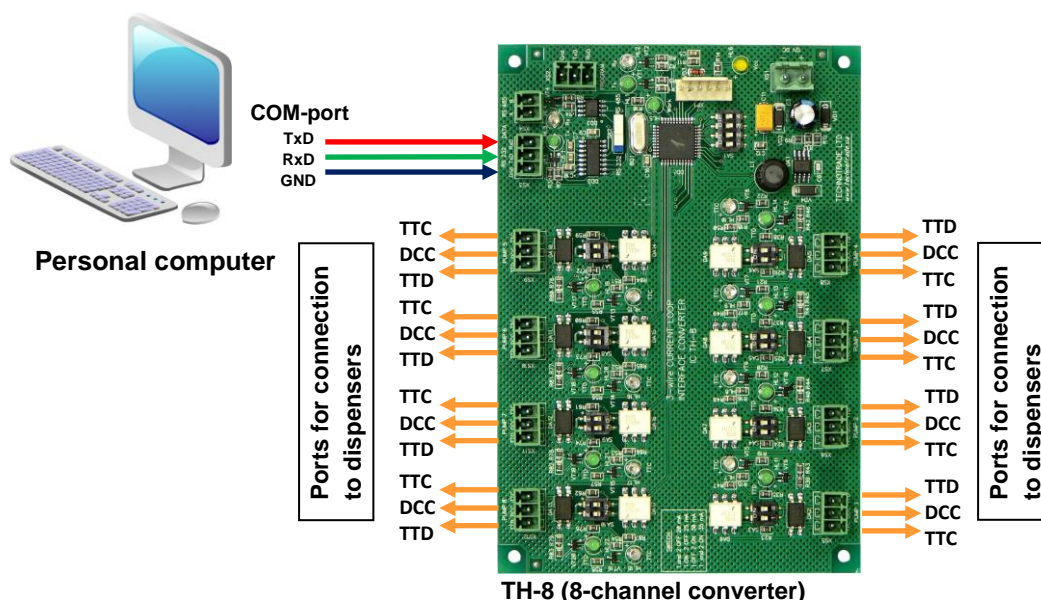

At connection using RS-232 interface please check the following:

- ✓ **DIP-switch SA1:**
 - switch 1 should be set to position "OFF"
 - switch 2 should be set to position "OFF"
 - switch 3 should be set in position "OFF"
 - switch 4 should be set to position "OFF"
- ✓ **DIP-switch SA2** should be in position "RS-232"
- ✓ **LED "Work" (HL3 in TH-2 and HL5 in TH-8)**, which indicates normal operation of firmware, should be blinking with constant frequency
- ✓ **LED "Vcc" (HL4 in TH-2 and HL6 in HL-8)**, which indicates presence of 12 V DC on the board, should be constantly shining
- ✓ **Green and red LEDs "Tx" and "Rx" (HL9, HL10 in TH-2 and HL3, HL4 in TH-8)**, which indicate communication exchange in DATA PORT, should be blinking, which indicates communication with the personal computer over RS-232 interface:

- in case if both LEDs "Rx" and "Tx" are not blinking – there are no requests from the control system and no responses from the dispenser.
 - in case if LED "Rx" is blinking and LED "Tx" is not blinking – there are requests from the control system (LED "Rx" is blinking), but there are no responses from the dispenser.
 - in case if LED "Rx" is blinking and LED "Tx" is blinking – there are requests from the control system (LED "Rx" is blinking) and there are responses from the dispenser (LED "Tx" is blinking).
- ✓ **LEDs on pump ports**, where the dispenser is connected, should be blinking, which indicates communication with the dispenser
- ✓ **DIP-switches on pump ports**, where dispensers are connected, should be set in accordance with a current value in TTD line of current loop. Possible current values:
- switch 1 OFF, switch 2 OFF => 20 mA
 - switch 1 ON, switch 2 OFF => 25 mA
 - switch 1 OFF, switch 2 ON => 30 mA
 - switch 1 ON, switch 2 ON => 35 mA

CONNECTION TO POWER SUPPLY

It is recommended to use non-shielded cable at connection to power supply. It is recommended to install a ferrite ring core TDK ZCAT 2235-1030 on the power supply cable with 1 coil inside (as shown on image below).



Ferrite ring core TDK ZCAT 2235-1030

Ferrite ring coil should be located on the power supply cable nearby (up to 3 cm) the power supply connector of converter board or nearby the power supply cable input of box (in case if converter is supplied in plastic box). After placing a ferrite ring on the power supply cable it is required to check correctness of its installation, it is possible to check it by moving ferrite ring along the power supply cable by pushing power supply cable into it from one side and pulling the cable from another side of the ferrite ring.

FIRMWARE UPDATE

Interface converter firmware is constantly being improved and new versions of firmware with improved functionality, new possibilities and fixed bugs of the previous firmware versions are proposed to be applied. Latest version of interface converter firmware is always available for downloading for customers.

Update of the interface converter firmware is made through a COM-port of personal computer using a built-in updater in *Pts_config.exe* utility. Please read more about the *Pts_config.exe* utility in PTS controller technical guide, which can be downloaded from PTS controller web-page http://www.technotrade.ua/fuel_pump_controller.html.

Scheme of connections of the TH-2 interface converter to personal computer:

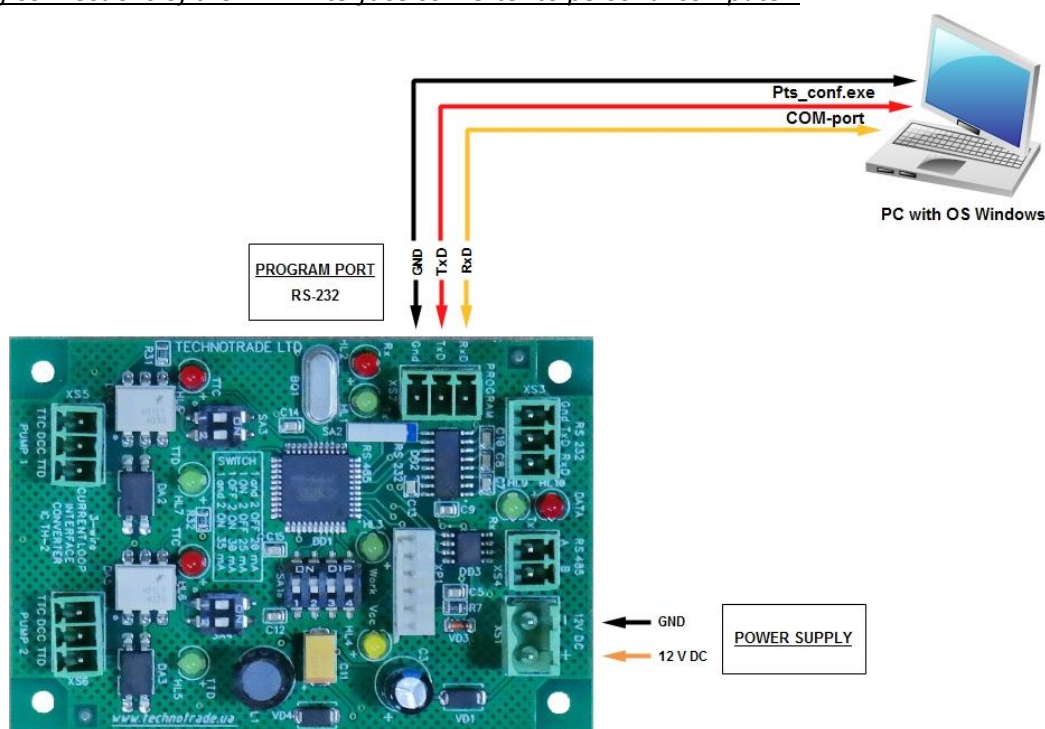

Scheme of connections of the TH-8 interface converter to personal computer:

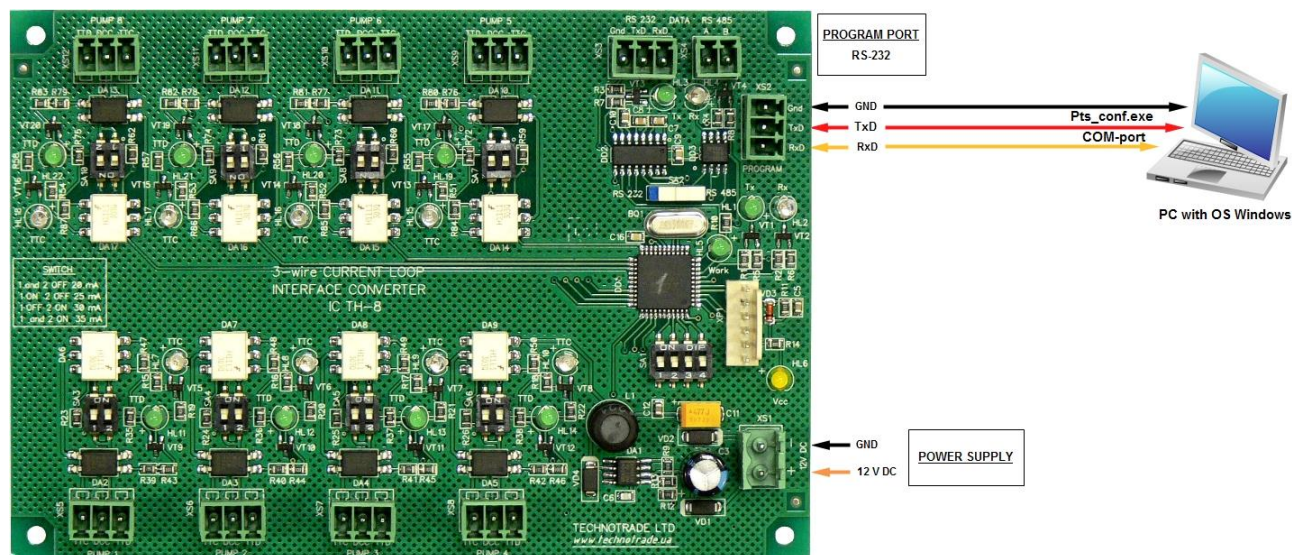

Before start of firmware update it is necessary to switch 4th DIP-switch SA1 on the interface converter to position ON. After the firmware update process is complete it is recommended to set the 4th DIP-switch SA1 to position OFF.

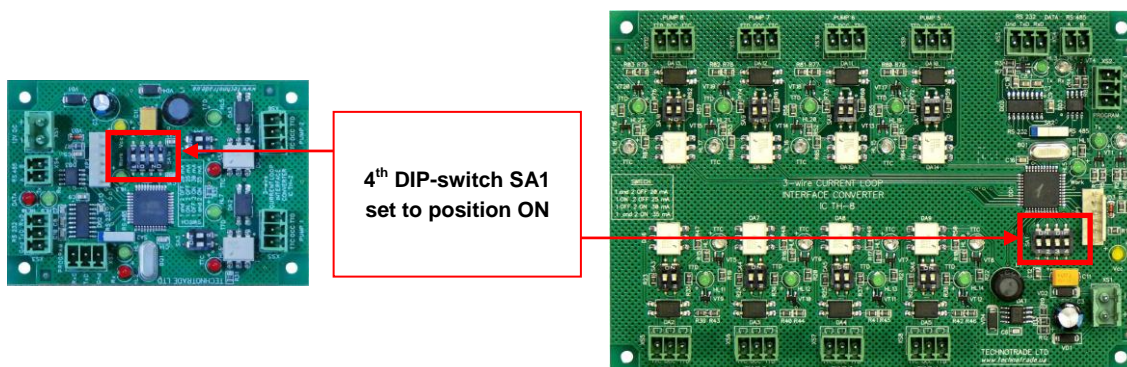

In *Pts_config.exe* utility leave a COM-port closed and go to tab “Firmware update”. On the opened form select a COM-port of connected interface converter, path to a file with a new firmware and press a button “Start update”. Firmware will start to be updated. Wait until the process is finished. In case of any errors - restart a tool and try again.

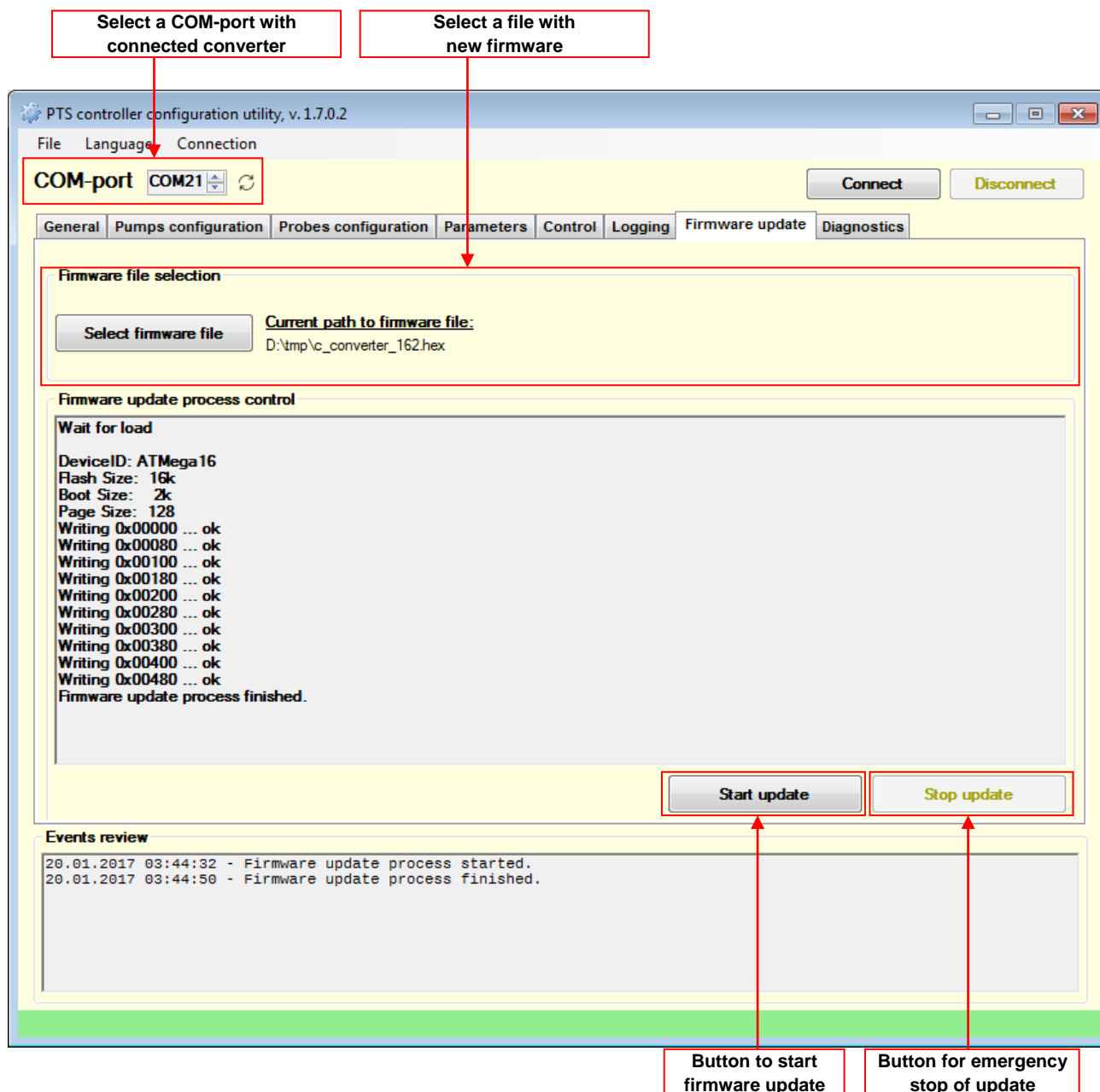

In case if the firmware is not being updated – power off the interface converter, click to start firmware update and power on the interface converter. At this the firmware update process should start.

NOTE! In order to prevent interface converter firmware from accidental update it is strictly recommended to keep 4th DIP-switch SA1 in OFF position in any moment of time except for firmware update needs.

INSTALLATION REQUIREMENTS FOR PETROL STATION

WARNING! Manufacturer guarantees reliable and stable operation of products only at compliance with below requirements. In case of absence of uninterruptible power supply or incorrect wiring of products to it any claims to malfunction of software are not accepted.

1. Requirements to power supply

The described products come into structure of control system (POS) for petrol station. Power supply of the products should be done from a separate power supply with built-in filter of radio frequency interferences and limiter of high voltage pulse interferences. Power supply should have a safety factor of 1.5.

At emergency switching off the power supply or in case of power voltage exceeding its permitted ranges the products can switch off with loss or corruption of data and possible damage of hardware and software. Power supply of all electronic blocks of POS and electronic pumpheads of dispensers, which are connected through information lines, should be made from single common uninterruptible power supply source (UPS). Connection of other devices to given UPS is strictly prohibited. UPS should be of continuous action (online) and work with double conversion with output voltage regulation. UPS should have a safety factor of 1.5. Filter of radio frequency interferences and limiter of high voltage pulse interferences should be used for feeding equipment from UPS.

Supply of electronic pumpheads of dispensers should be made from the UPS unit using 3-wires scheme with isolated neutral through dedicated two-pole breaker for each dispenser. Connection of other parts of dispenser to UPS unit (except electronic pumpheads) is strictly prohibited.

UPS unit should be connected to a separate three-pole socket fed through the three-wire feeder (phase, neutral, ground wires) with insulated neutral from a dedicated circuit breaker of switchboard. Feeder coming from the switchboard to the socket should be located not closer than 0.3 meters to other feeders. The socket should be located at a distance of not more than 1 meter away from the POS. Phase wire of the feeder should not have any other consumer, which are sources of interferences (for example motors).

For protection of POS and UPS from secondary effects of atmospheric electricity it is required to install high-voltage arresters (dischargers) at the transformer substation or on poles of power lines.

2. Requirements to grounding

In the switchboard the ground wire of feeder socket should be connected to the grounding screw, which should be connected by means of welding with a protection grounding circuit of petrol station by steel wire with a diameter of not less than 5 mm.

Protection grounding circuit of petrol station should correspond to safety requirements and be separated from the station lightning protection circuit. Distance from the nearest electrode of protection grounding circuit to electrode of lightning protection circuit must be at least 10 meters. Resistance of the protection grounding circuit should be not more than 4 Ohms and must be confirmed by the test report. Length of wires from the switchboard to the nearest electrode of protection grounding circuit should not exceed 15 meters.

3. Requirements to laying of cable communications

Laying of power and information wires to dispensers should be done in separate pipes with distance of not less than 0.3 meters between each other. For informational wires (current loops, RS-485, other interfaces)

it is recommended to use shielded twisted-pair cables (recommended type – FTP CAT 5E). The cable shield must be connected to the ground connector on one side only – on the side of the dispenser.

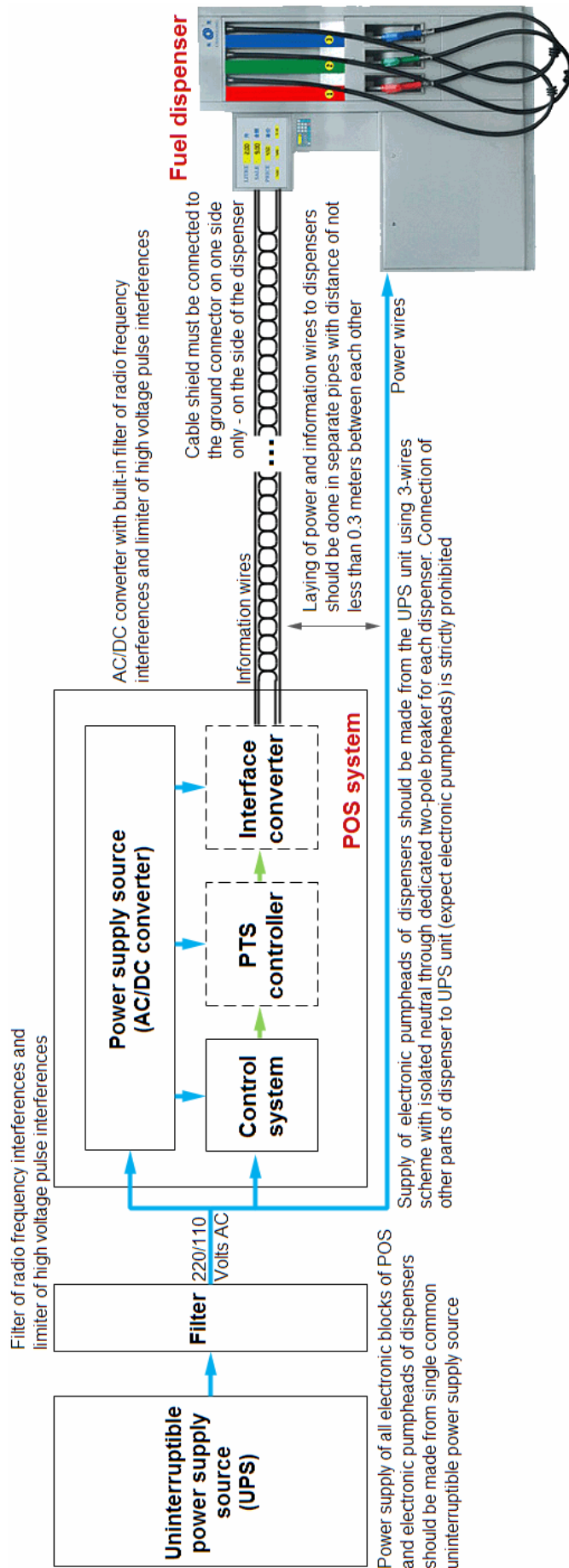

EXAMPLES OF FUEL DISPENSERS CONNECTION SCHEMES

Tokheim dispenser connection schemes



Tokheim dispenser board

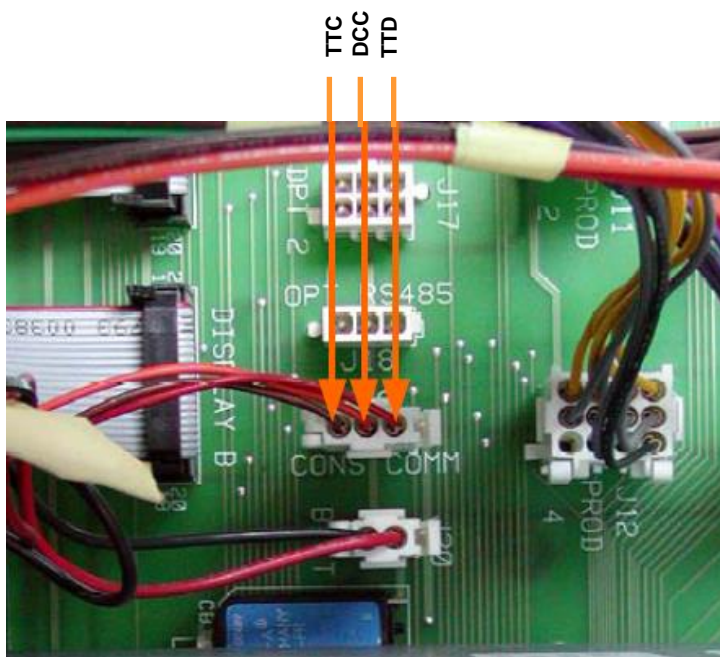

Tokheim dispenser board

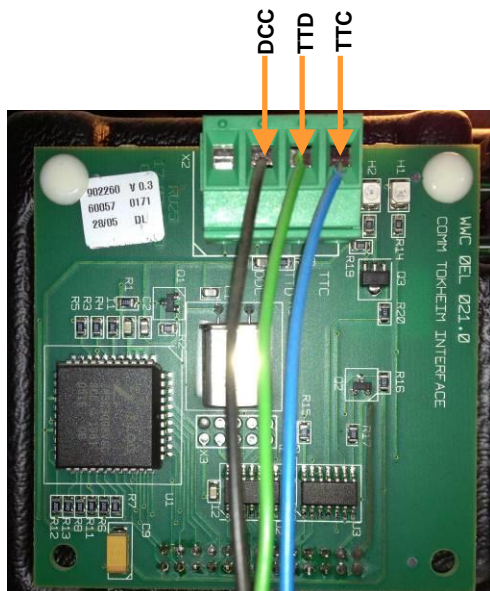

Tokheim dispenser interface board

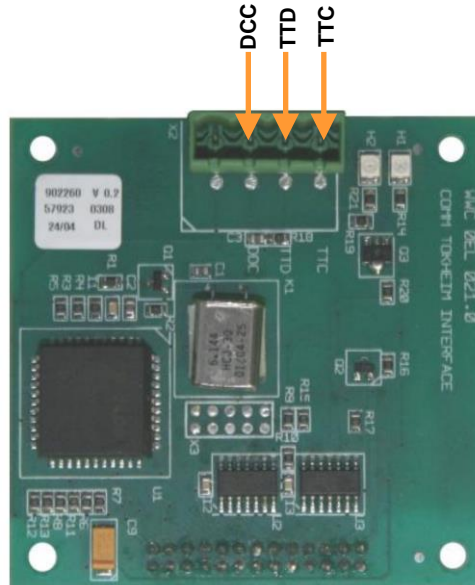

Tokheim dispenser interface board

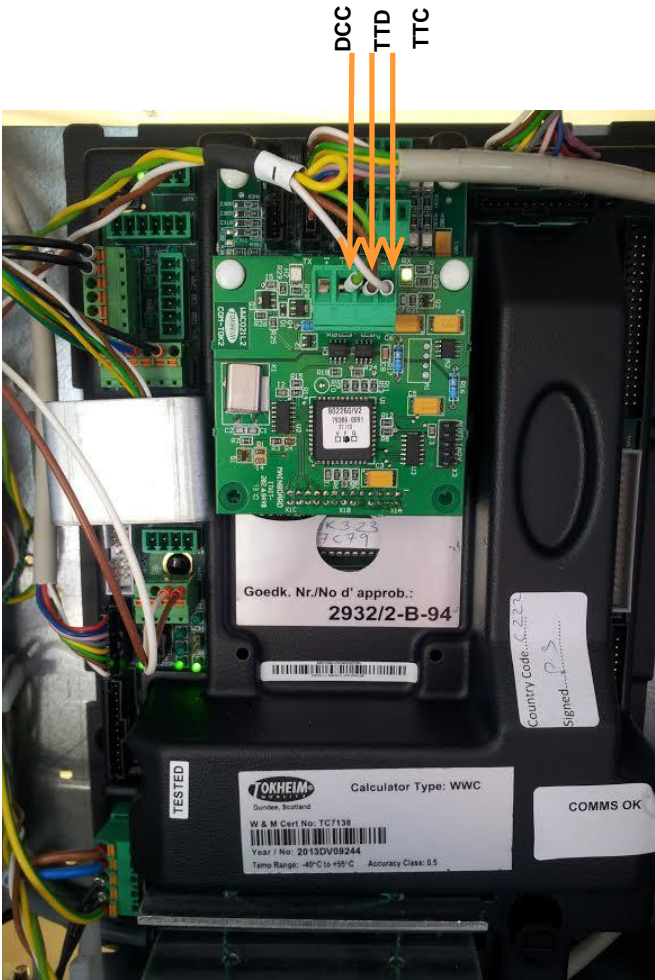

Tokheim dispenser calculator with interface board

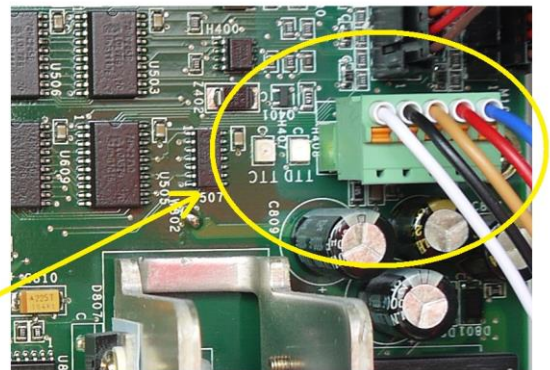

Tokheim Q320T dispenser calculator

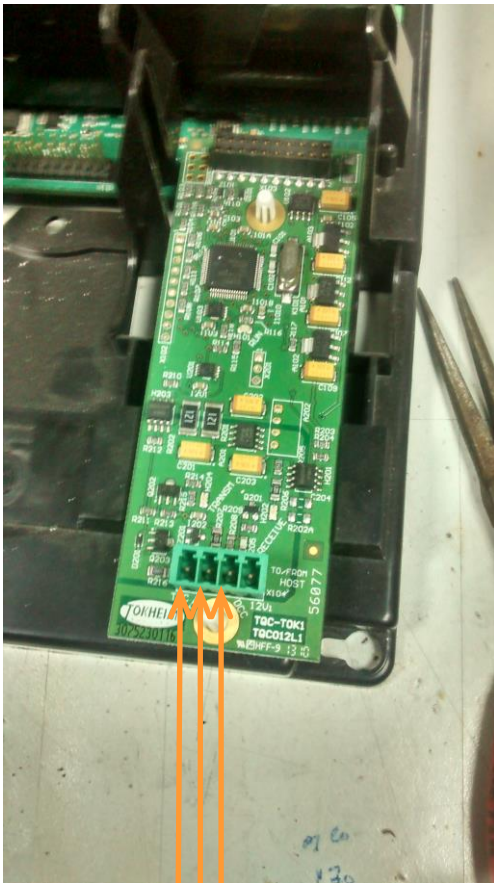

TTC
TTD
DCC

*Tokheim dispenser Q410 calculator
with interface board*

PCB MOUNTING BOARD

TH-2 (2-channel converter):

Top view:

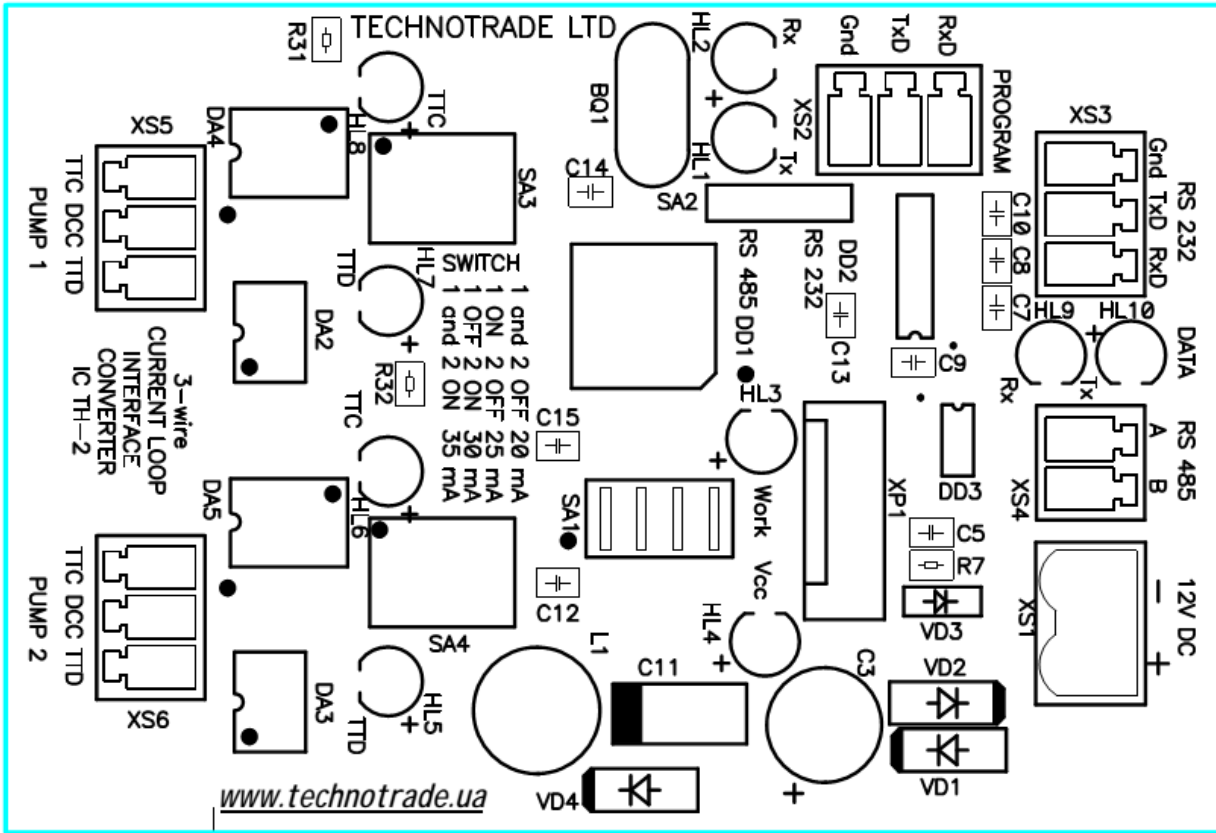

Bottom view:

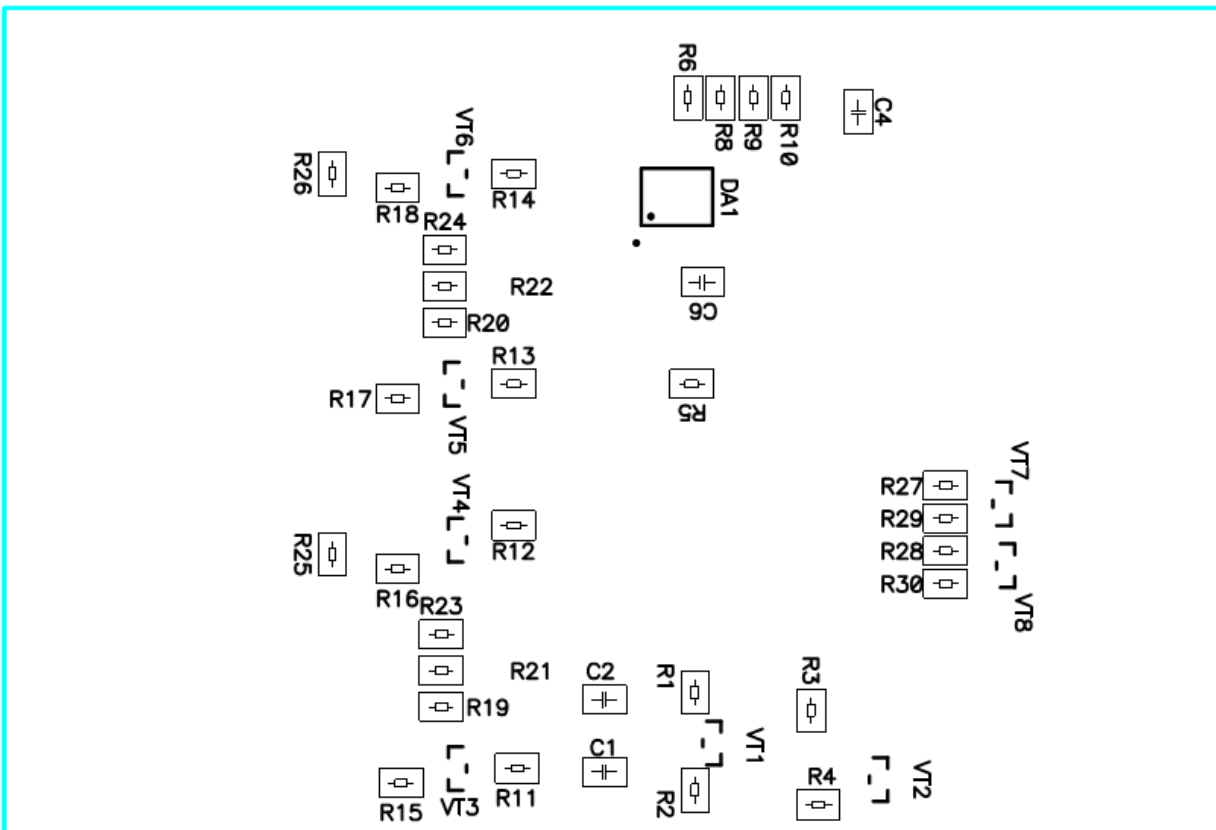

TH-8 (2-channel converter):

Top view:

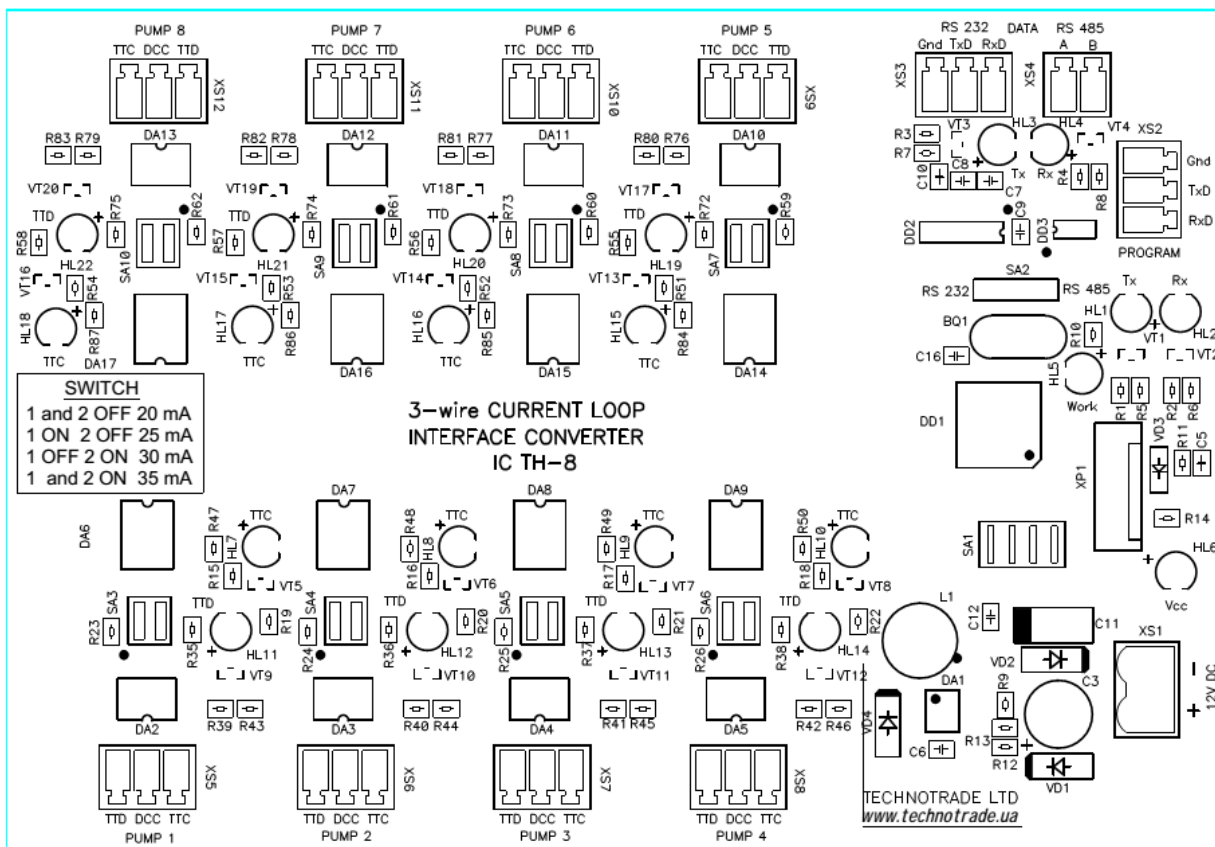

Bottom view:



ORDER INFORMATION

Variant of TH interface converter supply is marked with THx-y-z, where

- x – quantity of channels on the interface converter (2 – for 2-channel interface converter, 8 – for 8 – channels interface converter type);
- y – type of supply:
 - o “PCB” in case if TH interface converter is supplied in a view of electric board;
 - o “BOX” in case if TH interface converter is supplied installed in plastic box with hermetic inputs for connection of wires and a button for power supply switching;
- z – variant of supply:
 - o 001 – variant of supply with installed terminal blocks for controller ports
 - o 002 – variant of supply without terminal blocks for controller ports (connection is made using connectors for stubs)

Examples of order:

- order of TH2 interface converter in a view of electric board: TH2-PCB-001;
- order of TH8 interface converter installed in a plastic box: TH8-BOX-001.