

LP interface converter

3-wire current loop interface converter
(RS-485/RS-232 to 3-wire current loop and backwards)

TECHNICAL GUIDE

(PCB board modification: LP-4)

Review date: 21 March, 2020

CONTENT

REVISION HISTORY	3
PURPOSE OF THE DOCUMENT	4
APPOINTMENT	5
TECHNICAL SPECIFICATIONS	6
COMPLETE SET	7
PCB BOARD CONNECTORS OVERVIEW	8
CONNECTION SCHEME TO PTS CONTROLLER	9
CONNECTION SCHEME TO PC COM-PORT (DATA COMMUNICATION).....	11
FIRMWARE UPDATE	12
INSTALLATION REQUIREMENTS FOR PETROL STATION	14
EXAMPLES OF FUEL DISPENSERS CONNECTION SCHEMES.....	16
Emgaz Dragon / Fornovo LPG dispenser with EsiWelma pumphead connection scheme.....	16
Logitron dispenser connection scheme.....	17
ORDER INFORMATION	18

REVISION HISTORY

REV	DATE	BY	SECTION	DESCRIPTION
1.07	2020.03.21	Evgeniy Vasyliiev	All	Regular document review
1.06	2017.01.20	Evgeniy Vasyliiev	Firmware update procedure	Firmware update procedure using 4 th DIP-switch SA1
1.05	2016.04.15	Evgeniy Vasyliiev	LP-8 board	LP-8 board
1.04	2014.10.22	Evgeniy Vasyliiev	Installation requirements for petrol station	Requirements to power supply, requirements to grounding, requirements to laying of cable communications
1.03	2014.08.01	Evgeniy Vasyliiev	Firmware update procedure	Description on how to update converter firmware Position of DIP-switch SA1 specified
1.02	2013.30.11	Evgeniy Vasyliiev	Connection schemes	Position of DIP-switch SA1 specified
1.01	2013.01.11	Evgeniy Vasyliiev	All	First release

PURPOSE OF THE DOCUMENT

This Technical Guide is intended for studying of LP interface converter for fuel dispensers for petrol stations. It contains basic information regarding its

- technical characteristics
- board interfaces and connectors
- configuration
- schemes of connection to fuel dispensers
- cabling

Information regarding connection to specific fuel dispensers and correspondent configuration of LP interface converter can be received upon request to Technotrade LLC company.

During the system development process given Technical Guide is also expanded and updated and new chapters are added. Latest version of this Technical Guide can be downloaded from the LP interface converter web-page: <http://www.technotrade.ua/logitron-interface-converter.html>.

Technotrade LLC hereby permits reproduction of this document as may be required by any of the customers or OEMs wishing to use it.

This document has been carefully prepared and is believed to be accurate. However, Technotrade LLC, its employees and its agents do not assume responsibility for its use either directly or indirectly. Technotrade LLC shall not be liable for technical or editorial errors or omissions which may appear in this document. Technotrade LLC reserves a right to make changes to this document at any time without notice. Prospective users of this document should contact Technotrade LLC at the time they wish to use LP interface converter together with their products to become aware of any updates that may apply.

In case if you find any mistakes, omissions in this document or have any suggestions on improvements to this document, please feel free to e-mail them to our support mailbox: support_1a@technotrade.ua. We will be grateful to you for this valuable information.

All technical questions regarding the LP interface converter are welcome to be asked on support mailbox: support_1a@technotrade.ua. Our support team will be glad to help you.

Also, you can call to us or visit us on:

Technotrade LLC

Ukraine, 04114 Kiev, Priorska str. 10, office 1

Tel: +38-044-502-46-55, +38-044-502-46-77

Web: www.technotrade.ua

Mail: mail@technotrade.ua

APPOINTMENT

LP interface converters (**RS-485/RS-232 to 3-wire current loop and backwards**) is intended for communication with fuel dispensers, which use 3-wire current loop interface, through interfaces:

- RS-232
- RS-485 (2-wire)

LP interface converters can be applied for communication with following brands of fuel dispensers, which use 3-wire current loop for communication with control systems:

- **Logitron**
- **Emgaz Dragon**
- **Gilbarco Marconi**
- **EsiWelma**
- **Fornovo LPG**
- *others*

TECHNICAL SPECIFICATIONS

Specification

PARAMETER	VALUE
Power supply voltage	12 V DC
Current consumption	200 mA max
Temperature range	From -40°C to +80°C
Weight	45 g
Dimensions	85 x58 x 25 mm

Communication ports

PORT NAME		INTERFACE	PURPOSE
DATA PORTS	RS-232	RS-232 (3 wires: TxD, RxD, Gnd)	Communication with a control system (POS terminal, cash register, OPT). Selection of interface is made using DIP-switch.
	RS-485	RS-485 (2-wires: line A, line B)	
PUMP PORTS	Pump ports 1...4 (3-wire current loop)	Optically isolated active current loop	Connection with fuel dispensers using 3 wires. One dispenser is to be connected to each of the pump ports. Selection of current value in current loop of each pump port is made using DIP-switches in pump ports.
PROGRAM PORT	RS-232	RS-232 (3 wires: TxD, RxD, Gnd)	Update of the interface converter firmware

COMPLETE SET

Depending on the order code (see section "Order information") LP interface can be supplied either in a view of electrical board (variant of converter supply *LP4-PCB-z*), or installed in a mounting box with cables inputs and a power switching button (variant of converter supply *LP4-BOX-z*).

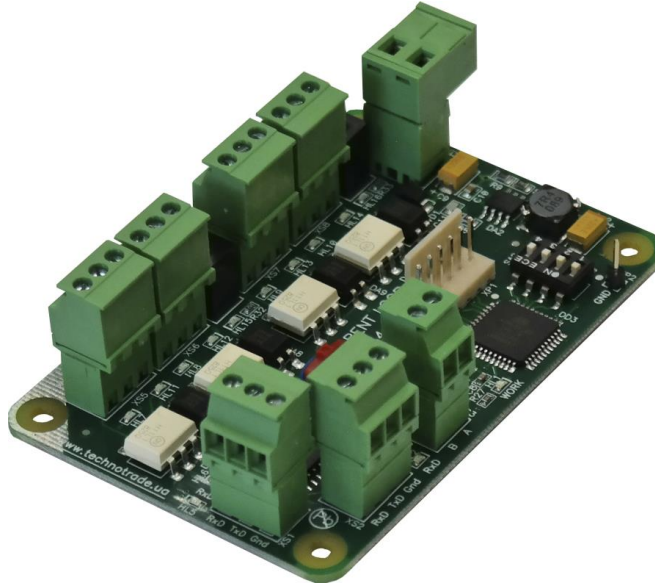

Variant of LP-4 interface converter supply in a view of electrical board (LP4-PCB-z)



Variant of LP-4 interface converter supply installed in a plastic box with cables inputs and power switching button (LP4-BOX-z)

PCB BOARD CONNECTORS OVERVIEW

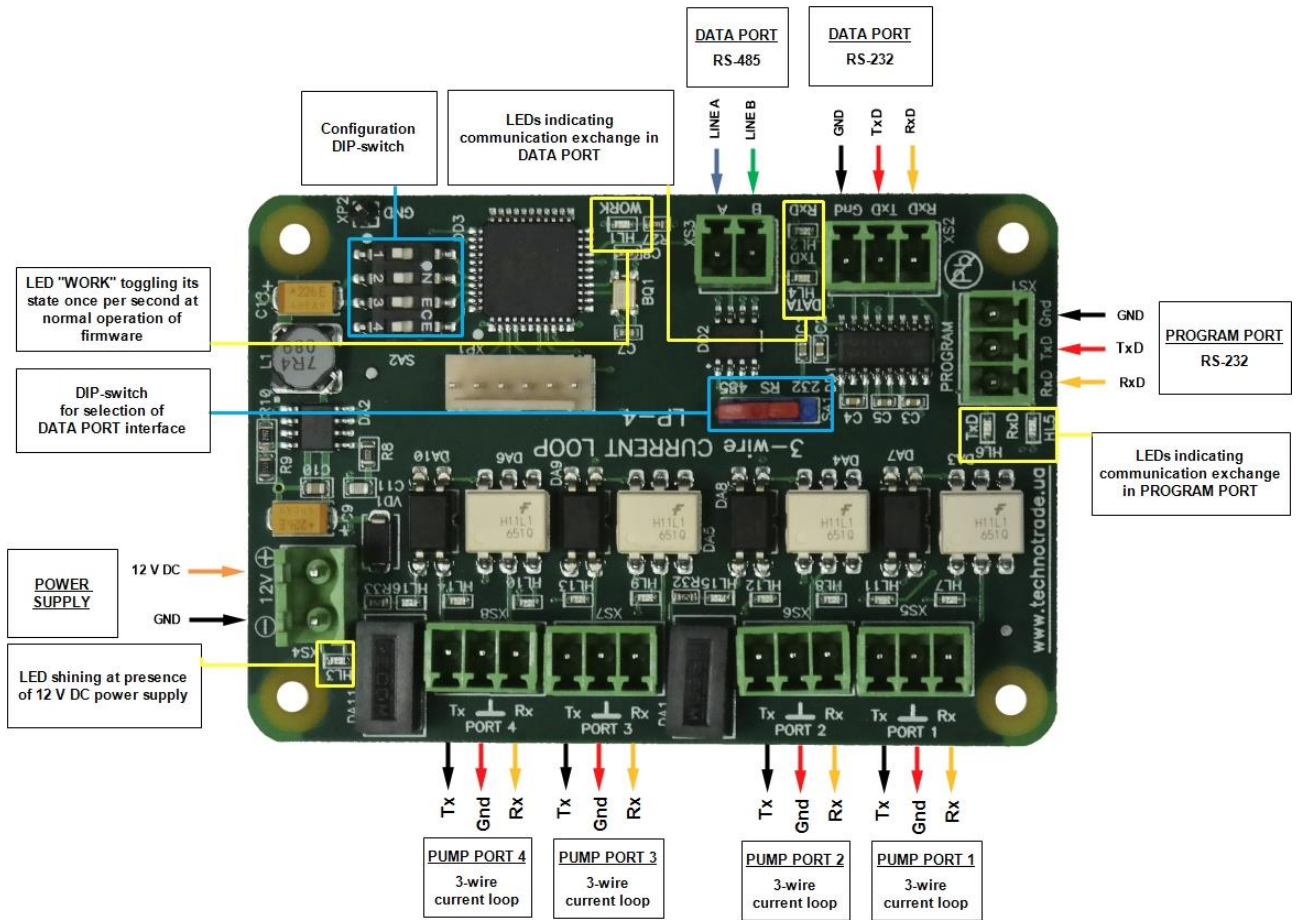

NOTE!

Configuration DIP-switch SA2 serves for selection of interface converter operation mode:

- switch 1 should be set in position "OFF"
- switch 2 should be set in position "OFF"
- switch 3 should be set in position "OFF"
- switch 4 should be set in position "OFF"

DIP-switch SA1 serves for selection of interface:

- RS-232
- RS-485 (2-wire)

CONNECTION SCHEME TO PTS CONTROLLER

Connection scheme to PTS-1 controller (information about PTS controller over fuel dispensers and ATG systems can be found on PTS-1 controller web-page: <http://www.technotrade.ua/fuel-pump-controller.html>):

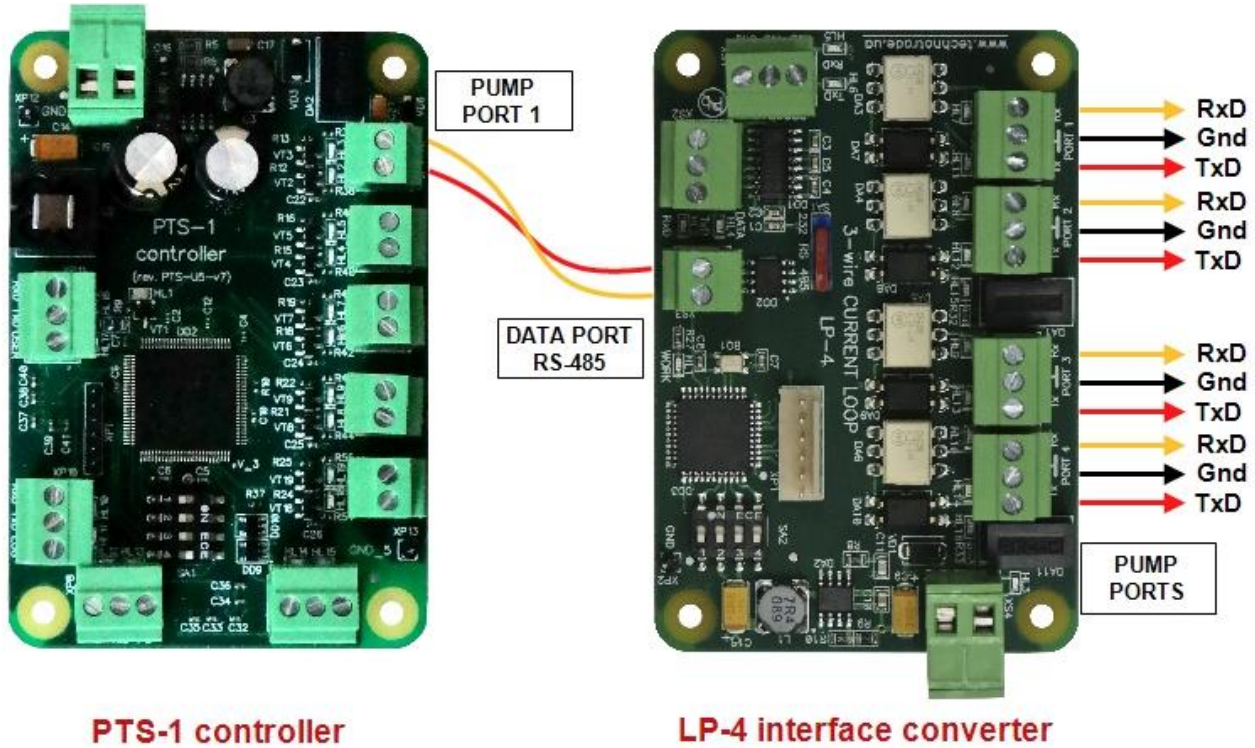

PTS-1 controller

LP-4 interface converter

Connection scheme to PTS-2 controller (information about PTS controller over fuel dispensers and ATG systems can be found on PTS-2 controller web-page: <http://www.technotrade.ua/pts2-forecourt-controller.html>):

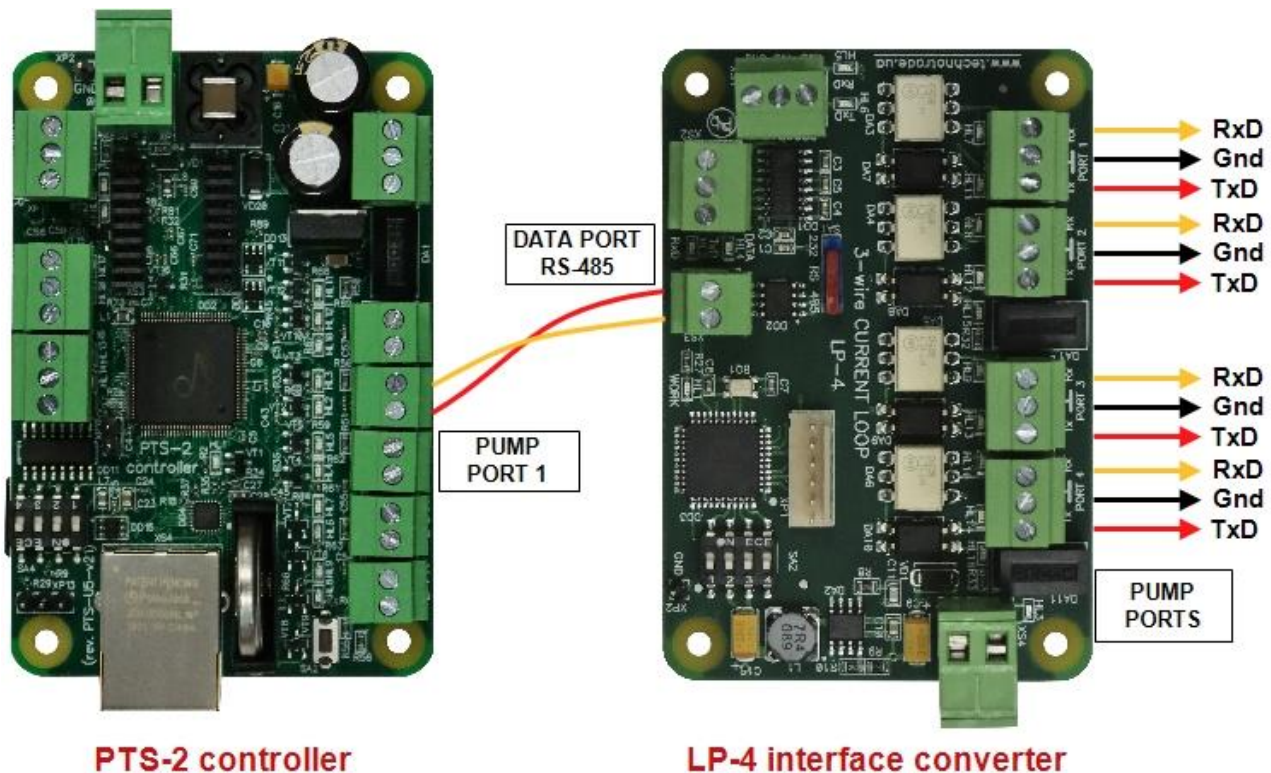

PTS-2 controller

LP-4 interface converter

At connection using RS-485 interface please check the following:

- ✓ **DIP-switch SA2:**
 - switch 1 should be set to position "OFF"
 - switch 2 should be set to position "OFF"
 - switch 3 should be set in position "OFF"
 - switch 4 should be set to position "OFF"
- ✓ **DIP-switch SA1** should be in position "RS-485"
- ✓ **LED HL1 "WORK"** indicates normal operation of firmware, toggling its state once per second
- ✓ **LED HL3** indicates presence of 12 V DC on the board, should be constantly shining
- ✓ **Green and red LEDs "Tx" and "Rx"**, which indicate communication exchange in DATA PORT, should be blinking, which indicates communication with the PTS controller over RS-485 interface:
 - in case if both LEDs "Rx" and "Tx" are not blinking – there are no requests from the control system and no responses from the dispenser.
 - in case if LED "Rx" is blinking and LED "Tx" is not blinking – there are requests from the control system (LED "Rx" is blinking), but there are no responses from the dispenser.
 - in case if LED "Rx" is blinking and LED "Tx" is blinking – there are requests from the control system (LED "Rx" is blinking) and there are responses from the dispenser (LED "Tx" is blinking).
- ✓ **LEDs on pump ports**, where the dispenser is connected, should be blinking, which indicates communication with the dispenser

CONNECTION SCHEME TO PC COM-PORT (DATA COMMUNICATION)

Control over dispensers through the interface converter from a personal computer:

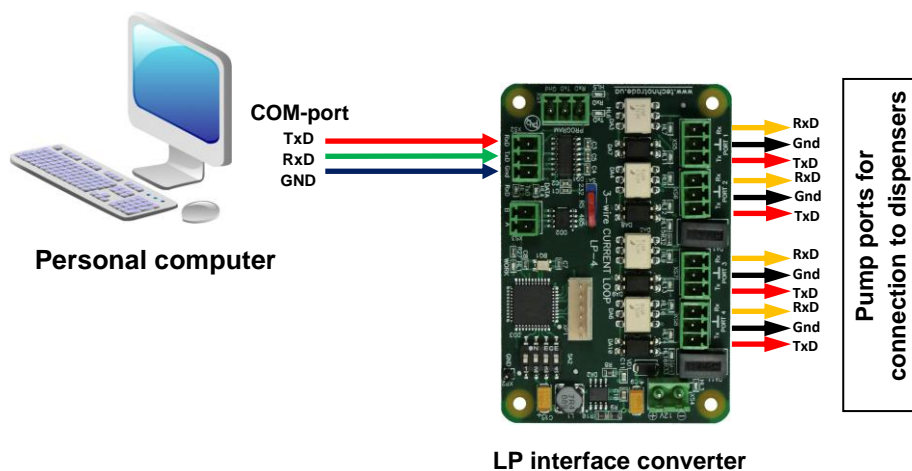

At connection using RS-232 interface please check the following:

- ✓ **DIP-switch SA2:**
 - switch 1 should be set to position "OFF"
 - switch 2 should be set to position "OFF"
 - switch 3 should be set in position "OFF"
 - switch 4 should be set to position "OFF"
- ✓ **DIP-switch SA1** should be in position "RS-232"
- ✓ **LED HL1 "WORK"** indicates normal operation of firmware, toggling its state once per second
- ✓ **LED HL3** indicates presence of 12 V DC on the board, should be constantly shining
- ✓ **Green and red LEDs "Tx" and "Rx"**, which indicate communication exchange in DATA PORT, should be blinking, which indicates communication with the PTS controller over RS-485 interface:
 - in case if both LEDs "Rx" and "Tx" are not blinking – there are no requests from the control system and no responses from the dispenser.
 - in case if LED "Rx" is blinking and LED "Tx" is not blinking – there are requests from the control system (LED "Rx" is blinking), but there are no responses from the dispenser.
 - in case if LED "Rx" is blinking and LED "Tx" is blinking – there are requests from the control system (LED "Rx" is blinking) and there are responses from the dispenser (LED "Tx" is blinking).
- ✓ **LEDs on pump ports**, where the dispenser is connected, should be blinking, which indicates communication with the dispenser

FIRMWARE UPDATE

LP interface converter’s firmware is constantly being improved and new versions of firmware with improved functionality, new possibilities and fixed bugs of the previous firmware versions are proposed to be applied. Latest version of interface converter firmware is always available for downloading for customers.

Update of the interface converter firmware is made through a COM-port of personal computer using a built-in updater in *Pts_config.exe* utility. Please read more about the *Pts_config.exe* utility in PTS controller technical guide, which can be downloaded from PTS controller web-page http://www.technotrade.ua/fuel_pump_controller.html.

Scheme of connections of the LP interface converter to personal computer:

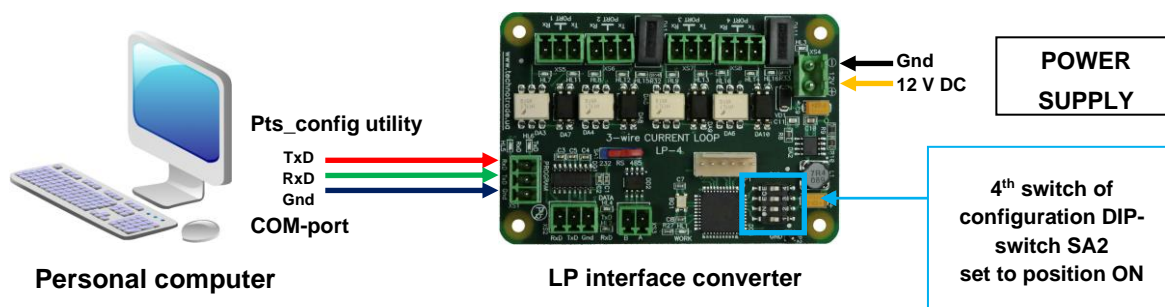

Before start of firmware update it is necessary to 4th switch of configuration DIP-switch SA2 on LP interface converter to position *ON*. After the firmware update process is complete it is strongly recommended to set 4th switch of configuration DIP-switch SA2 back to position *OFF*.

In *Pts_config.exe* utility leave a COM-port closed and go to tab “Firmware update”. On the opened form select a COM-port of connected interface converter, path to a file with a new firmware and press a button “Start update”. Firmware will start to be updated. Wait until the process is finished. In case of any errors - restart a tool and try again.

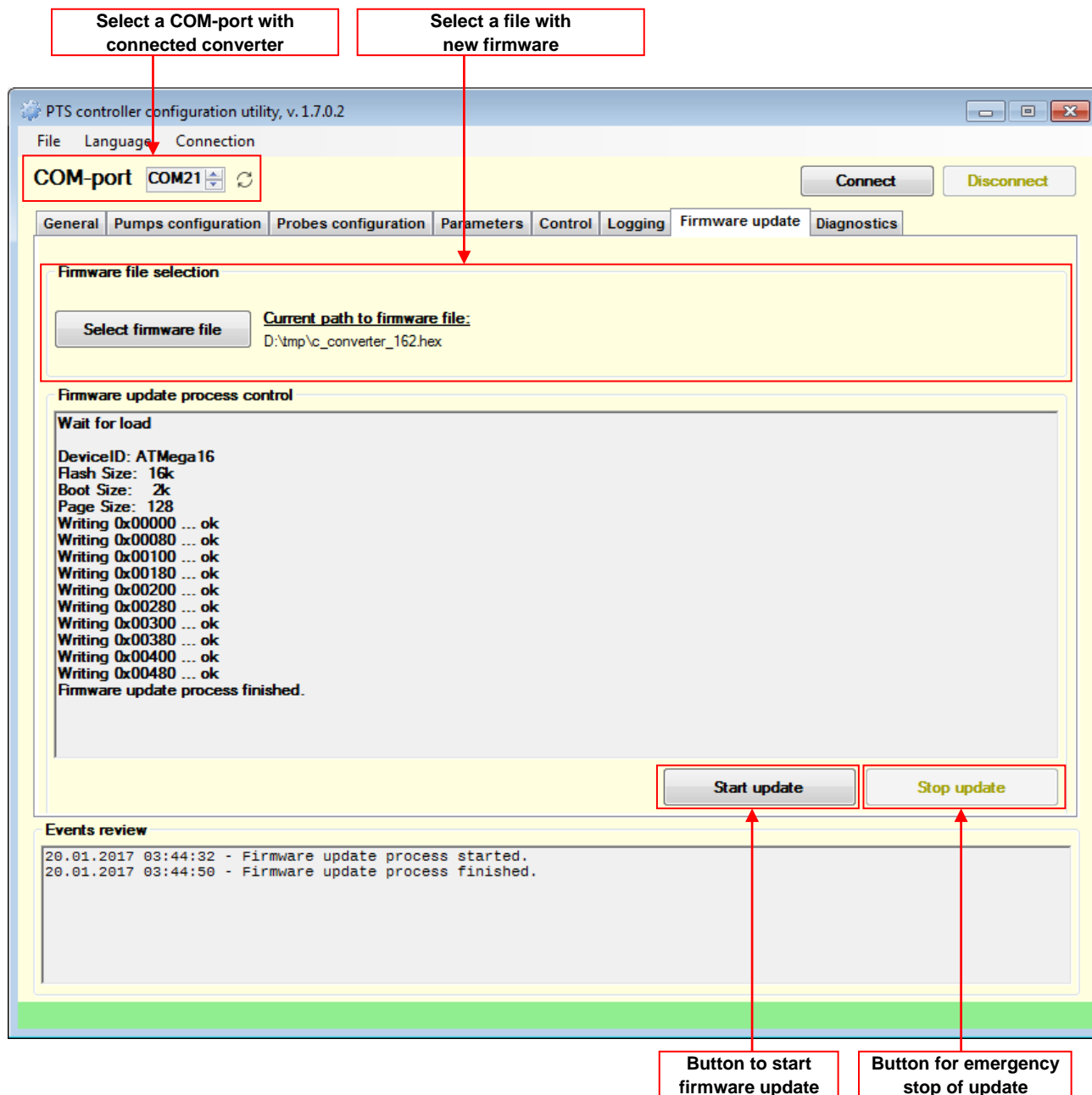

In case if the firmware is not being updated – power off the interface converter, click to start firmware update and power on the interface converter. At this the firmware update process should start.

NOTE! In order to prevent interface converter firmware from accidental update it is strictly recommended to keep 4th switch of configuration DIP-switch SA2 in OFF position in any moment of time except for firmware update needs.

INSTALLATION REQUIREMENTS FOR PETROL STATION

WARNING! Manufacturer guarantees reliable and stable operation of products only at compliance with below requirements. In case of absence of uninterruptible power supply or incorrect wiring of products to it any claims to malfunction of software are not accepted.

1. Requirements to power supply

The described products come into structure of control system (POS) for petrol station. Power supply of the products should be done from a separate power supply with built-in filter of radio frequency interferences and limiter of high voltage pulse interferences. Power supply should have a safety factor of 1.5.

At emergency switching off the power supply or in case of power voltage exceeding its permitted ranges the products can switch off with loss or corruption of data and possible damage of hardware and software. Power supply of all electronic blocks of POS and electronic pumpheads of dispensers, which are connected through information lines, should be made from single common uninterruptible power supply source (UPS). Connection of other devices to given UPS is strictly prohibited. UPS should be of continuous action (online) and work with double conversion with output voltage regulation. UPS should have a safety factor of 1.5. Filter of radio frequency interferences and limiter of high voltage pulse interferences should be used for feeding equipment from UPS.

Supply of electronic pumpheads of dispensers should be made from the UPS unit using 3-wires scheme with isolated neutral through dedicated two-pole breaker for each dispenser. Connection of other parts of dispenser to UPS unit (except electronic pumpheads) is strictly prohibited.

UPS unit should be connected to a separate three-pole socket fed through the three-wire feeder (phase, neutral, ground wires) with insulated neutral from a dedicated circuit breaker of switchboard. Feeder coming from the switchboard to the socket should be located not closer than 0.3 meters to other feeders. The socket should be located at a distance of not more than 1 meter away from the POS. Phase wire of the feeder should not have any other consumer, which are sources of interferences (for example motors).

For protection of POS and UPS from secondary effects of atmospheric electricity it is required to install high-voltage arresters (dischargers) at the transformer substation or on poles of power lines.

2. Requirements to grounding

In the switchboard the ground wire of feeder socket should be connected to the grounding screw, which should be connected by means of welding with a protection grounding circuit of petrol station by steel wire with a diameter of not less than 5 mm.

Protection grounding circuit of petrol station should correspond to safety requirements and be separated from the station lightning protection circuit. Distance from the nearest electrode of protection grounding circuit to electrode of lightning protection circuit must be at least 10 meters. Resistance of the protection grounding circuit should be not more than 4 Ohms and must be confirmed by the test report. Length of wires from the switchboard to the nearest electrode of protection grounding circuit should not exceed 15 meters.

3. Requirements to laying of cable communications

Laying of power and information wires to dispensers should be done in separate pipes with distance of not less than 0.3 meters between each other. For informational wires (current loops, RS-485, other interfaces)

it is recommended to use shielded twisted-pair cables (recommended type – FTP CAT 5E). The cable shield must be connected to the ground connector on one side only – on the side of the dispenser.

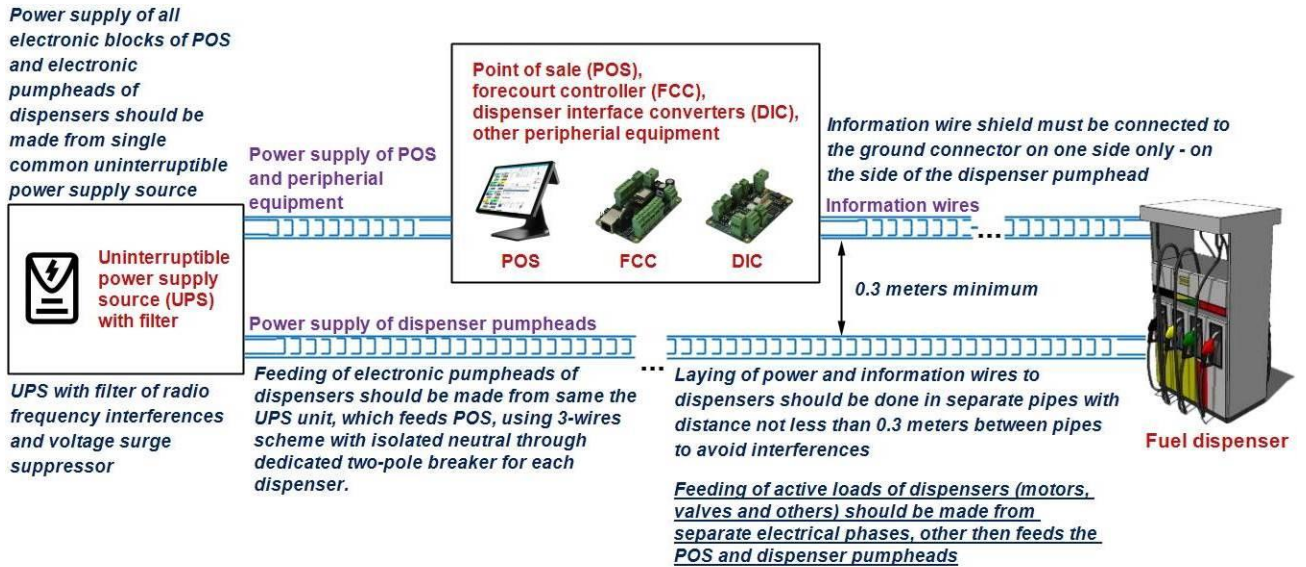

4. Requirements to connection of ATG probes

Connection of ATG probes installed inside the tanks should be done only with provision of required safety measures: in case if probes have explosion-proof protection – then armored cables should be used, in case if probes have intrinsic safety – then connection should be performed through suitable safety barriers.

EXAMPLES OF FUEL DISPENSERS CONNECTION SCHEMES

Emgaz Dragon / Fornovo LPG dispenser with EsiWelma pumphead connection scheme

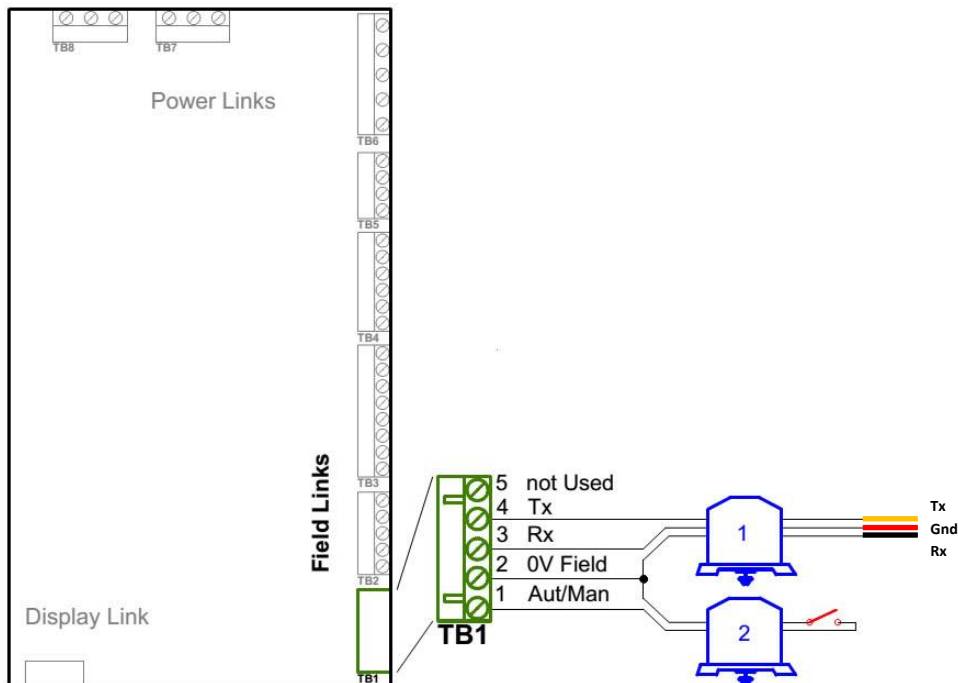

Logitron dispenser connection scheme

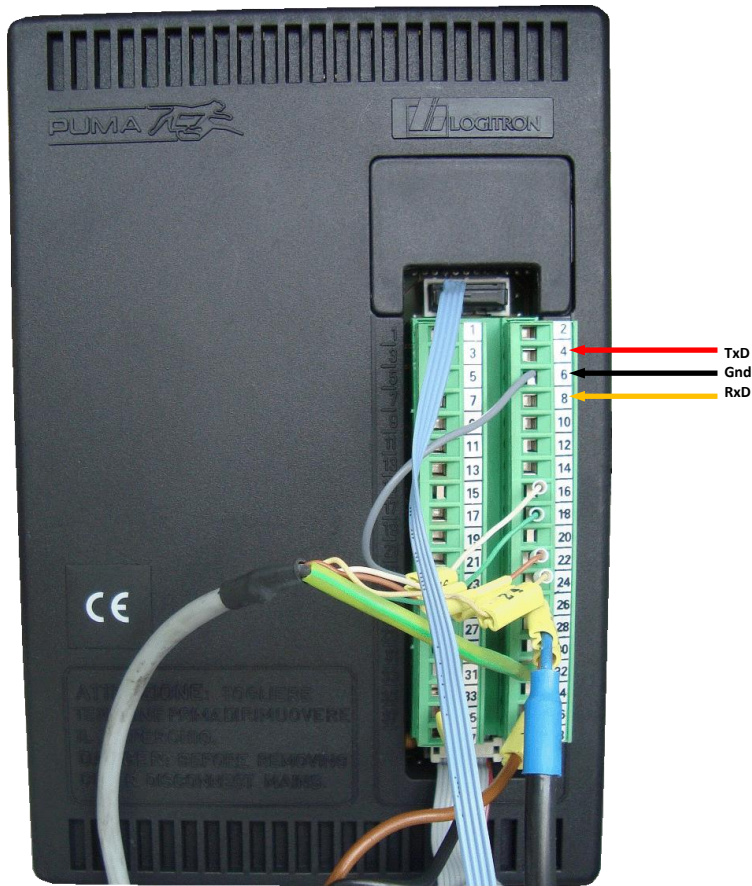

ORDER INFORMATION

Variant of LP-4 interface converter supply is marked with LP4-y-z, where

- y – type of supply:
 - “PCB” in case if LP interface converter is supplied in a view of electric board;
 - “BOX” in case if LP interface converter is supplied installed in plastic box with hermetic inputs for connection of wires and a button for power supply switching;
- z – variant of supply:
 - 001 – variant of supply with installed terminal blocks for controller ports
 - 002 – variant of supply without terminal blocks for controller ports (connection is made using connectors for stubs)

Examples of order:

- order of LP-4 interface converter in a view of electric board: LP4-PCB-001;
- order of LP-4 interface converter installed in a plastic box: LP4-BOX-001.